

PRE-WIRED STRING BOXES

PRODUCTS FOR PV APPLICATION





DC STRING BOXES

DIRECT CURRENT



DC String boxes must be positioned between the strings of PV panels and the inverter, to guarantee **protection** and **isolation** of the connection between the two parts.

The string boxes are made using specific components for the protection and wiring of a **single string**, **two strings in parallel** or **two independent strings**. Furthermore, it is possible to request **customized** configurations with wiring adapted to the type of PV system.

Pre-wired string boxes with nominal voltage of **600 Vdc** and **1000 Vdc** are available, with overvoltage protection via **type 2 Surge Protective Devices (SPD)**, overcurrent protection via **fuse holders base (fuses included)**, and isolation via **disconnect switches** specific for **DC-PV1** and **DC-PV2** use categories (according to IEC EN 60947-3).

Installation both **indoors** and **outdoors**, thanks to enclosures made of insulating material with IP65 protection degree.

Electrical cabinets made in compliance with the harmonized technical standards IEC EN 61439-1/2.

S
N
O
T
I
O
N
S
S
N
O
T
I
O
N
S





1 STRING

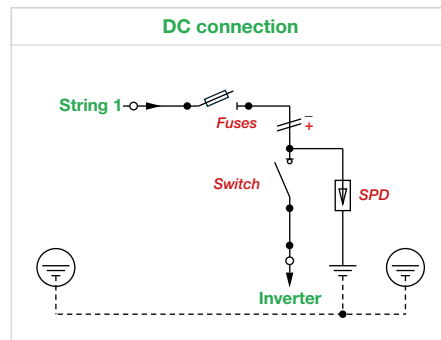
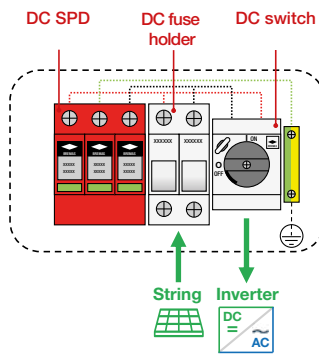

2 PARALLEL STRINGS

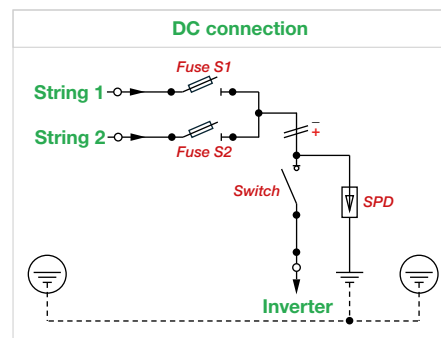
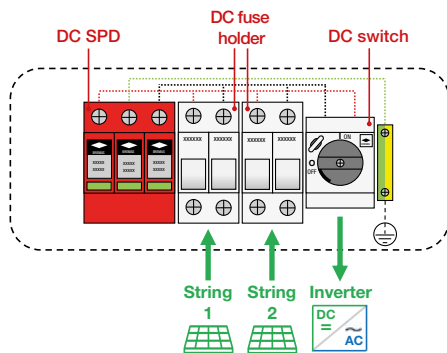

2 SINGLE STRINGS

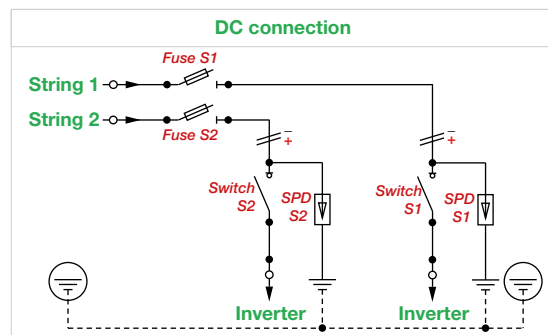
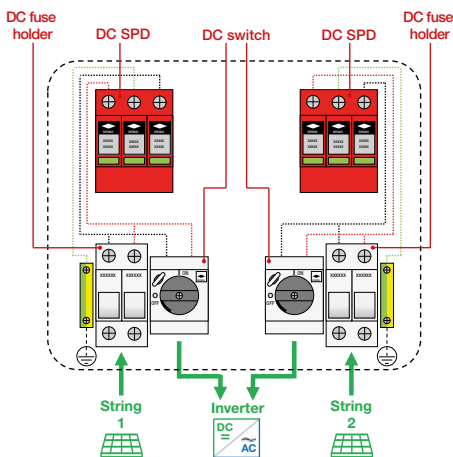

DC STRING BOXES

DIRECT CURRENT



■ 1 string 600 Vdc

code MBDC060L0101F20

- 1x DC input - 1x DC output
- 1x Bremas DP100121E0ADRLE disconnect switch, 32 A at 600 Vdc (DC-PV1)
- 1x Bremas SAPV060T2 Surge Protective Device, 600 Vdc, In=18 kA, Type 2
- 1x fuse holder base 1000 Vdc, 32 A (gPV) + 2x gPV fuse 20 A
- Enclosure in insulating material, 8 DIN modules, 1 row, IP65

■ 1 string 1000 Vdc

code MBDC100L0101F20

- 1x DC input - 1x DC output
- 1x Bremas DX120301E0ADRLE disconnect switch, 30 A at 1000 Vdc (DC-PV1)
- 1x Bremas SAPV100T2 Surge Protective Device, 1040 Vdc, In=18 kA, Type 2
- 1x fuse holder base 1000 Vdc, 32 A (gPV) + 2x gPV fuse 20 A
- Enclosure in insulating material, 8 DIN modules, 1 row, IP65



■ 2 parallel strings 600 Vdc

code MBDC060L0201F20

- 2x DC inputs - 1x DC output
- 1x Bremas DP100121E0ADRLE disconnect switch, 32 A at 600 Vdc (DC-PV1)
- 1x Bremas SAPV060T2 Surge Protective Device, 600 Vdc, In=18 kA, Type 2
- 2x fuse holder base 1000 Vdc, 32 A (gPV) + 4x gPV fuse 20 A
- Enclosure in insulating material 12 DIN modules, 1 row, IP65

■ 2 parallel strings 1000 Vdc

code MBDC100L0201F20

- 2x DC inputs - 1x DC output
- 1x Bremas DX120301E0ADRLE disconnect switch, 30 A at 1000 Vdc (DC-PV1)
- 1x Bremas SAPV100T2 Surge Protective Device, 1040 Vdc, In=18 kA, Type 2
- 2x fuse holder base 1000 Vdc, 32 A (gPV) + 4x gPV fuse 20 A
- Enclosure in insulating material 12 DIN modules, 1 row, IP65

■ 2 single strings 600 Vdc

code MBDC060L0202F20

- 2x DC inputs - 2x DC outputs
- 2x Bremas DP100121E0ADRLE disconnect switch, 32 A at 600 Vdc (DC-PV1)
- 2x Bremas SAPV060T2 Surge Protective Device, 600 Vdc, In=18 kA, Type 2
- 2x fuse holder base 1000 Vdc, 32 A (gPV) + 4x gPV fuse 20 A
- Enclosure in insulating material 24 DIN modules, 2 rows, IP65

■ 2 single strings 1000 Vdc

code MBDC100L0202F20

- 2x DC inputs - 2x DC outputs
- 2x Bremas DX120301E0ADRLE disconnect switch, 30 A at 1000 Vdc (DC-PV1)
- 2x Bremas SAPV100T2 Surge Protective Device, 1040 Vdc, In=18 kA, Type 2
- 2x fuse holder base 1000 Vdc, 32 A (gPV) + 4x gPV fuse 20 A
- Enclosure in insulating material 24 DIN modules, 2 rows, IP65

AC/DC STRING BOXES

ALTERNATING AND DIRECT CURRENT



The AC/DC string boxes provide **protection and isolation** of the DC connection between the strings of photovoltaic panels and the inverter, and all the protection and management components of the AC connection downstream of the inverter.

Both connections are contained in a **single** cabinet, divided into two sections isolated from each other:

- the DC connection, with nominal voltage of **600 Vdc** and **1000 Vdc**, provides overvoltage protection via type 2 Surge Protective Devices (SPD), overcurrent protection via **fuse holders base (fuses included)**, and isolation via **disconnect switches** specific for DC-PV1 and DC-PV2 use categories (according to IEC EN 60947-3 standard);
- the AC connection, for **single-phase 230 Vac** systems, provides overvoltage protection via a **type 2 Surge Protective Devices**, and automatic interruption via a **Residual Current Circuit Breaker with Overcurrent Protection (RCBO)**.

Standard electrical cabinets specific to the protection and wiring of a **single string**, **two strings in parallel**, or two independent strings. Furthermore, it is possible to request **customized** configurations with wiring adapted to the type of photovoltaic and electrical systems.

Installation both **indoors** and **outdoors**, thanks to containers made of insulating material with IP65 protection degree. Electrical cabinets made in compliance with the harmonized technical standards **IEC EN 61439-1/2**.

S
N
O
I
T
T
U
T
S





SINGLE-PHASE - 1 STRING

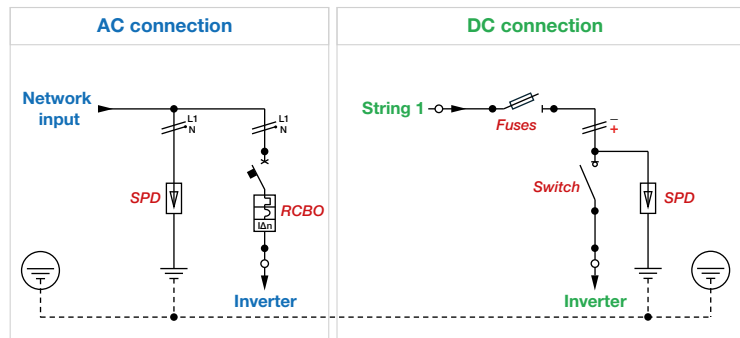
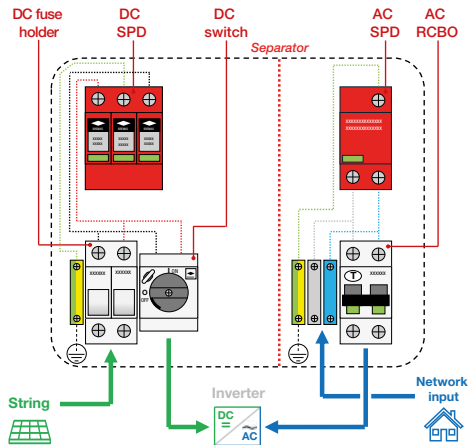

SINGLE-PHASE - 2 PARALLEL STRINGS

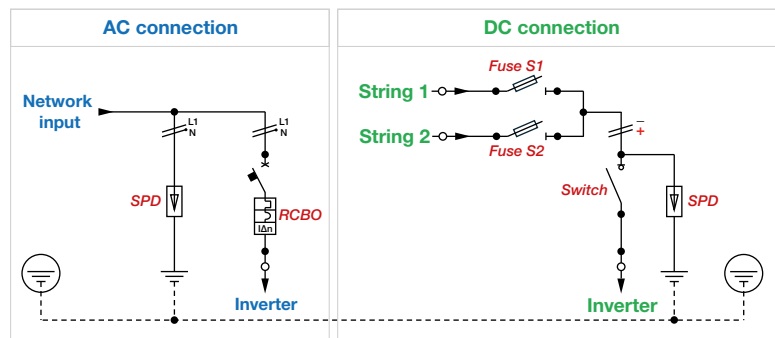
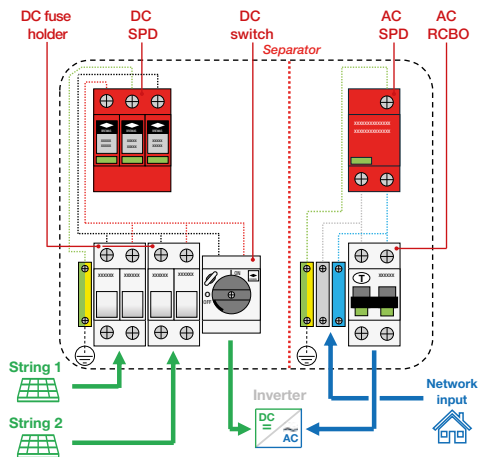

SINGLE-PHASE - 2 SINGLE STRINGS

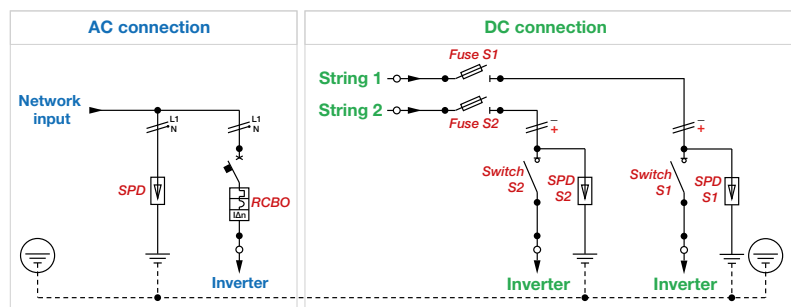
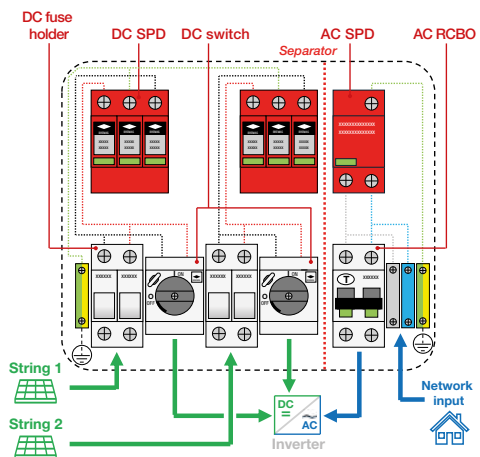

AC/DC STRING BOXES

ALTERNATING AND DIRECT CURRENT



■ Single-phase 16 A - 1 string 600 Vdc

code MBXC060L0101F20M16

AC connection

- . 1x AC input - 1x AC output
- . 1x automatic Residual Current Circuit Breaker (300 mA - Class A) with Overcurrent Protection (16 A - Curve C)
- . 1x 230 Vac Surge Protective Device, Type 2, for single-phase TT-TN systems

DC connection

- . 1x DC input - 1x DC output
- . 1x Bremas DPI00121E0ADRLE disconnect switch, 32 A at 600 Vdc (DC-PVI)
- . 1x Bremas SAPV060T2 Surge Protective Device, 600 Vdc, In=18 kA, Type 2
- . 1x fuse holder base 1000 Vdc, 32 A (gPV) + 2x gPV fuse 20 A

Box

- . Enclosure in insulating material 24 DIN modules, 2 rows, IP65
- . Internal separator (AC and DC sections)

■ Single-phase 16 A - 1 string 1000 Vdc

code MBXC100L0101F20M16

AC connection

- . 1x AC input - 1x AC output
- . 1x automatic Residual Current Circuit Breaker (300 mA - Class A) with Overcurrent Protection (16 A - Curve C)
- . 1x 230 Vac Surge Protective Device, Type 2, for single-phase TT-TN systems

DC connection

- . 1x DC input - 1x DC output
- . 1x Bremas DXI20301E0ADRND disconnect switch, 30 A at 1000 Vdc (DC-PVI)
- . 1x Bremas SAPV100T2 Surge Protective Device, 1040 Vdc, In=18 kA, Type 2
- . 1x fuse holder base 1000 Vdc, 32 A (gPV) + 2x gPV fuse 20 A

Box

- . Enclosure in insulating material 24 DIN modules, 2 rows, IP65
- . Internal separator (AC and DC sections)



■ Single-phase 25 A - 2 parallel strings 600 Vdc

code MBXC060L0201F20M25

AC connection

- 1x AC input - 1x AC output
- 1x automatic Residual Current Circuit Breaker (300 mA - Class A) with Overcurrent Protection (25 A - Curve C)
- 1x 230 Vac Surge Protective Device, Type 2, for single-phase TT-TN systems

DC connection

- 2x DC inputs - 1x DC output
- 1x Bremas DP100121E0ADRLE disconnect switch, 32 A at 600 Vdc (DC-PV1)
- 1x Bremas SAPV060T2 Surge Protective Device, 600 Vdc, In=18 kA, Type 2
- 2x fuse holder base 1000 Vdc, 32 A (gPV) + 4x gPV fuse 20 A

Box

- Enclosure in insulating material 24 DIN modules, 2 rows, IP65
- Internal separator (AC and DC sections)

■ Single-phase 25 A - 2 parallel strings 1000 Vdc

code MBXC100L0201F20M25

AC connection

- 1x AC input - 1x AC output
- 1x automatic Residual Current Circuit Breaker (300 mA - Class A) with Overcurrent Protection (25 A - Curve C)
- 1x 230 Vac Surge Protective Device, Type 2, for single-phase TT-TN systems

DC connection

- 2x DC inputs - 1x DC output
- 1x Bremas DX120301E0ADRND disconnect switch, 30 A at 1000 Vdc (DC-PV1)
- 1x Bremas SAPV100T2 Surge Protective Device, 1040 Vdc, In=18 kA, Type 2
- 2x fuse holder base 1000 Vdc, 32 A (gPV) + 4x gPV fuse 20 A

Box

- Enclosure in insulating material 24 DIN modules, 2 rows, IP65
- Internal separator (AC and DC sections)

■ Single-phase 32 A - 2 single strings 600 Vdc

code MBXC060L0202F20M32

AC connection

- 1x AC input - 1x AC output
- 1x automatic Residual Current Circuit Breaker (300 mA - Class A) with Overcurrent Protection (32 A - Curve C)
- 1x 230 Vac Surge Protective Device, Type 2, for single-phase TT-TN systems

DC connection

- 2x DC inputs - 2x DC outputs
- 2x Bremas DP100121E0ADRLE disconnect switch, 32 A at 600 Vdc (DC-PV1)
- 2x Bremas SAPV060T2 surge arrester, 600 Vdc, In=18 kA, Type 2
- 2x fuse holder base 1000 Vdc, 32 A (gPV) + 4x gPV fuse 20 A

Box

- Enclosure in insulating material 24 DIN modules, 2 rows, IP65
- Internal separator (AC and DC sections)

■ Single-phase 32 A - 2 single strings 1000 Vdc

code MBXC100L0202F20M32

AC connection

- 1x AC input - 1x AC output
- 1x automatic Residual Current Circuit Breaker (300 mA - Class A) with Overcurrent Protection (32 A - Curve C)
- 1x 230 Vac Surge Protective Device, Type 2, for single-phase TT-TN systems

DC connection

- 2x DC inputs - 2x DC outputs
- 2x Bremas DX120301E0ADRND disconnect switch, 30 A at 1000 Vdc (DC-PV1)
- 2x Bremas SAPV100T2 Surge Protective Device, 1040 Vdc, In=18 kA, Type 2
- 2x fuse holder base 1000 Vdc, 32 A (gPV) + 4x gPV fuse 20 A

Box

- Enclosure in insulating material 24 DIN modules, 2 rows, IP65
- Internal separator (AC and DC sections)



The **AC string boxes** provide **protection** and **management** of the AC connection downstream of the inverter in a photovoltaic system.

Pre-wired string boxes for mono-phase systems type with nominal voltage of **230 Vac** are available, with overvoltage protection via **type 2 Surge Protective Devices (SPD)**, and automatic interruption via **Residual Current Circuit Breaker with Overcurrent Protection (RCBO)**.

Furthermore, it is possible to request **customized** configurations with wiring adapted to the type of electrical system.

Installation both **indoors** and **outdoors**, thanks to containers made of insulating material with **IP65** protection rating.

Electrical cabinets made in compliance with the harmonized technical standards **IEC EN 61439-1/2**.



■ Single-phase 25 A

code MBACM25

- . 1x AC input - 1x AC output
- . 1x automatic Residual Current Circuit Breaker (300 mA - Class A) with Overcurrent Protection (25 A - Curve C)
- . 1x 230 Vac Surge Protective Device, Type 2, for single-phase TT-TN systems
- . Enclosure in insulating material, 8 DIN modules, 1 row, IP65

■ Single-phase 32 A

code MBACM32

- . 1x AC input - 1x AC output
- . 1x automatic Residual Current Circuit Breaker (300 mA - Class A) with Overcurrent Protection (32 A - Curve C)
- . 1x 230 Vac Surge Protective Device, Type 2, for single-phase TT-TN systems
- . Enclosure in insulating material, 8 DIN modules, 1 row, IP65



DC STRING BOXES

DIRECT CURRENT



AC/DC STRING BOXES

ALTERNATING AND DIRECT CURRENT



AC STRING BOXES

ALTERNATING CURRENT



Bremas Ersce SpA

Via Castellazzo, 9 - 20040 Cambiagio (MI) Tel. +39.02.95651611 Fax +39.02.95651639 - info@bremas.it
ISO 9001 Certified Quality System

bremas.it