

## Ultra Low Power CO<sub>2</sub> Sensor with T & R/H

### DESCRIPTION

The CozIR®-LP series is a set of low power NDIR CO<sub>2</sub> sensors using state-of-the-art solid-state LED optical technology. The low power LEDs are manufactured in-house, giving GSS complete control of the CO<sub>2</sub> sensor signal chain.

The CozIR®-LP series low power consumption is compatible with battery powered operation, allowing the sensor to be used in a wide variety of applications including wirelessly connected equipment.

The CozIR®-LP series operation is configurable depending on user requirements. Depending on type they can be set to stream data or for the ultimate in power saving can be set to take readings at intervals and consume no power between measurements.

The CozIR®-LP series also features a built-in auto-zero function that maintains CO<sub>2</sub> measurement accuracy over the lifetime of the product.

### FEATURES

- Low power CO<sub>2</sub> sensor
- +/- (30ppm+3%rdg) typical measurement accuracy
- Solid state NDIR LED optical technology
- UART control and data interface
- Built-in auto-zeroing

### APPLICATIONS

- Indoor Air Quality (IAQ)
- IoT and Smart Technology wireless equipment
- Air Quality and HVAC Systems
- Building Management Systems (BMS)
- Demand-Controlled Ventilation (DCV) systems
- Transport
- In-Cabin Air Quality

### BLOCK DIAGRAM

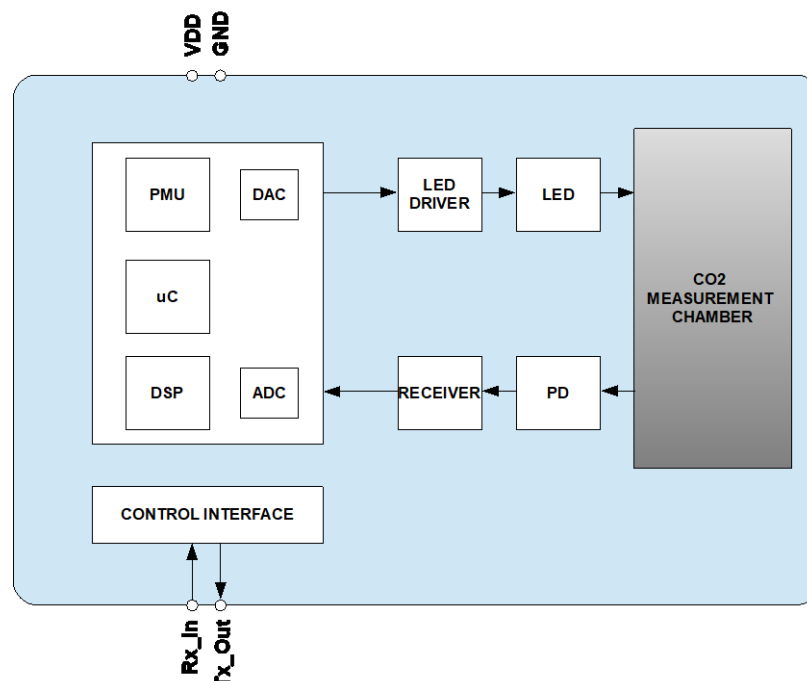

**Ultra Low Power CO<sub>2</sub> Sensor with T & R/H**

**TABLE OF CONTENTS**

DESCRIPTION .....	1
FEATURES .....	1
APPLICATIONS .....	1
BLOCK DIAGRAM .....	1
FEATURE MATRIX .....	4
ORDERING INFORMATION .....	4
PACKAGE DRAWINGS COZIR-LP1-2 .....	6
PINOUT COZIR-LP1-2 .....	7
PACKAGE DRAWINGS – COZIR-LP2-2 AND COZIR-BLINK-2 .....	8
PINOUT COZIR-LP2-2 AND COZIR-BLINK-2 .....	9
PACKAGE DRAWINGS COZIR-LP3-2 AND COZIR-BLINK-N-2 .....	10
PINOUT COZIR-LP3-2 AND COZIR-BLINK-N-2 .....	11
ABSOLUTE MAXIMUM RATINGS .....	12
RECOMMENDED OPERATING CONDITIONS .....	12
PERFORMANCE CHARACTERISTICS .....	13
ELECTRICAL CHARACTERISTICS .....	14
METHOD OF OPERATION – COZIR-LP1-2, COZIR-LP2-2, COZIR-LP3-2 .....	15
MODE 0 COMMAND MODE .....	15
MODE 1 STREAMING MODE .....	15
MODE 2 POLLING MODE .....	15
BLINK MODE .....	16
DATA READY .....	16
MEASUREMENT CYCLE .....	17
DIGITAL FILTER .....	18
ZEROING .....	19
ZERO POINT SETTING .....	19
ZERO IN A KNOWN GAS CONCENTRATION .....	19
ZERO IN NITROGEN .....	19
ZERO IN FRESH AIR .....	19
ZERO POINT ADJUSTMENT .....	20
AUTO-ZERO FUNCTION .....	20
AUTO-ZERO INTERVALS .....	20
AUTO-ZERO LEVEL .....	20
ALTITUDE COMPENSATION .....	21
CONTROL INTERFACE .....	22
UART MODE .....	23
CONTROL INTERFACE TIMING .....	23
UART COMMAND PROTOCOL .....	23
UART INTERFACE SUMMARY .....	24
SETTING AUTO-ZERO INTERVALS .....	27
Non BLINK .....	27
BLINK .....	27
SETTING CO <sub>2</sub> LEVEL TO BE USED IN AUTO ZEROING .....	28
SETTING CO <sub>2</sub> LEVEL TO BE USED FOR ZERO POINT SETTING .....	28
I <sup>2</sup> C MODE .....	29
INTERFACE TIMING .....	29
I <sup>2</sup> C REGISTER MAP .....	30
MEASUREMENT CONTROL – RO .....	31

**Ultra Low Power CO<sub>2</sub> Sensor with T & R/H**

CO2 LEVEL MEASUREMENT VALUE WITH STATUS BYTE – R2..... 31  
CO2 LEVEL MEASUREMENT VALUE ONLY – R52 ..... 31  
AUTO-ZERO INITIAL INTERVAL PERIOD – R6..... 31  
AUTO-ZERO INTERVAL PERIOD – R8 ..... 31  
AUTO-ZERO TARGET VALUE – R12..... 31  
ZERO IN FRESH AIR..... 31  
CONTROL VALUE – R20..... 31  
ZERO CONTROL – R5..... 32  
SERIAL NUMBER – R38..... 33  
ALARM OUTPUT ..... 33  
BUILT-IN SELF TEST ..... 33  
PWM CONTROL - R46 ..... 34  
AUTO-ZERO CONTROL – R78..... 34  
SELF-TEST – R80..... 34  
RUN TIME – R90 ..... 34  
ALTITUDE PRESSURE SETTING – R118..... 34

**Ultra Low Power CO<sub>2</sub> Sensor with T & R/H**

**FEATURE MATRIX**

Feature	LP1-2	LP2-2	LP3-2	BLINK-2/Blink-N-2
Temperature	Yes	Yes	Yes	Yes
Humidity	Yes	Yes	Yes	Yes
Programmable Pulse Width Modulation Output	No	Yes	Yes	Yes
Programmable Alarm Output	No	Yes	Yes	Yes
UART Interface	Yes	Yes	Yes	Yes
I2C Interface	No	Yes	Yes	Yes
Pin based connection	Yes	Yes	Optional	Optional

**ORDERING INFORMATION**

Product	Order Info	CO <sub>2</sub> Range (X)		
COZIR-LP1-2	L12-SEN-201-X	2000ppm	5000ppm	1%
COZIR-LP2-2	L22-SEN-201-X	2000ppm	5000ppm	1%
COZIR-LP3-2	L32-SEN-201-X	2000ppm	5000ppm	1%
COZIR-Blink-2	L22-SEN-203-X	2000ppm	5000ppm	1%
COZIR-Blink-N-2	L32-SEN-203-X	2000ppm	5000ppm	1%

**L12-SEN-201-X**

X	Measurement Range
2000	0-2000ppm
5000	0-5000ppm
1	0-1% (10000ppm)

**L22-SEN-201-X**

X	Measurement Range
2000	0-2000ppm
5000	0-5000ppm
1	0-1% (10000ppm)

**L32-SEN-201-X**

X	Measurement Range
2000	0-2000ppm
5000	0-5000ppm
1	0-1% (10000ppm)

**L22-SEN-203-X**

X	Measurement Range
2000	0-2000ppm
5000	0-5000ppm
1	0-1% (10000ppm)

**L32-SEN-203-X**

X	Measurement Range
2000	0-2000ppm
5000	0-5000ppm
1	0-1% (10000ppm)

## **Ultra Low Power CO<sub>2</sub> Sensor with T & R/H**

**Notes:**

1. Sensors are shipped individually or in trays.
2. Tray quantity = 50

See separate data sheet for CozIR®-LP series evaluation kit options.

**Ultra Low Power CO<sub>2</sub> Sensor with T & R/H**

**PACKAGE DRAWINGS COZIR-LP1-2**

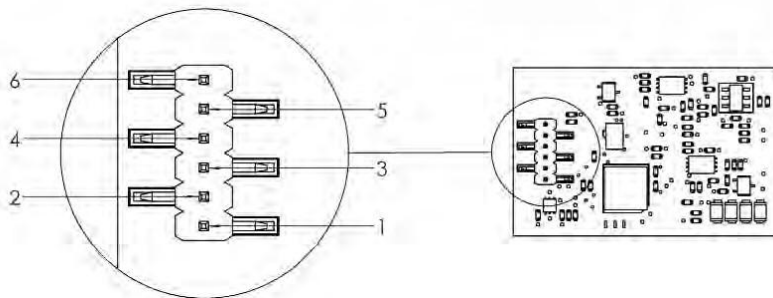
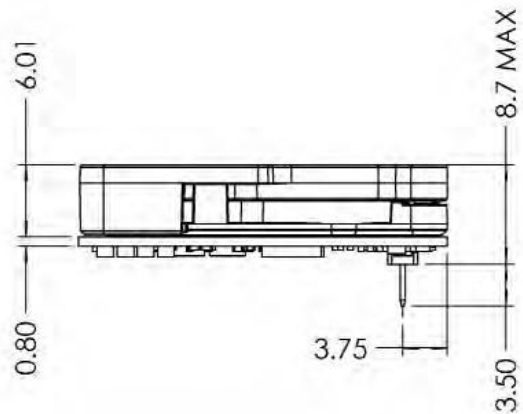
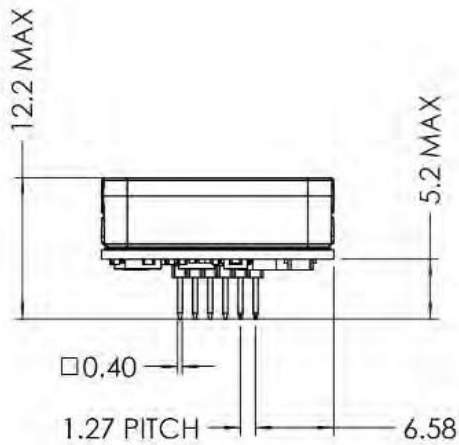
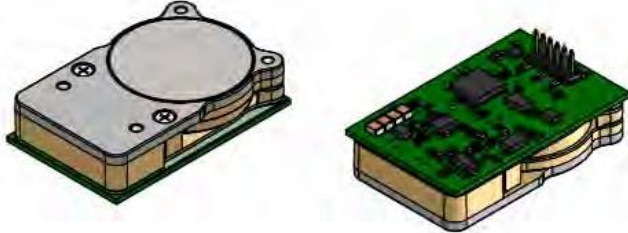
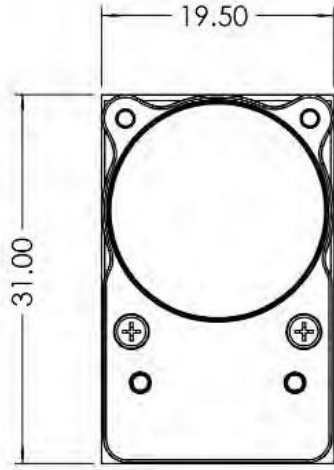

**Ultra Low Power CO<sub>2</sub> Sensor with T & R/H**

**PINOUT COZIR-LP1-2**

<b>PIN</b>	<b>NAME</b>	<b>TYPE</b>	<b>DESCRIPTION</b>
1	GND	Supply	Sensor ground
2	VDD	Supply	Sensor supply voltage
3	Rx_In	Digital Input	UART Receive Input
4	Tx_Out	Digital Output	UART Transmit Output
5	NC	Unused	Do not connect
6	NC	Unused	Do not connect

**Ultra Low Power CO<sub>2</sub> Sensor with T & R/H**

**PACKAGE DRAWINGS – COZIR-LP2-2 and COZIR-BLINK-2**

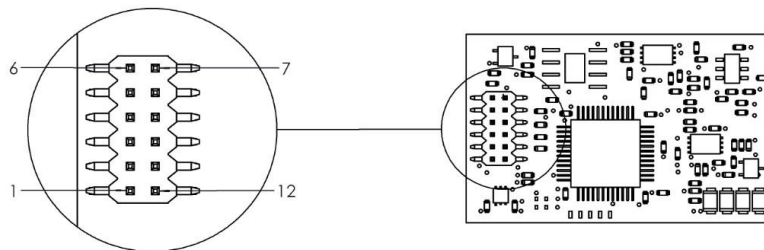
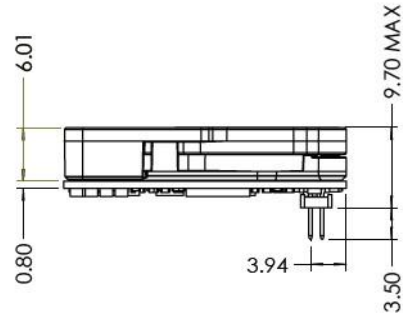
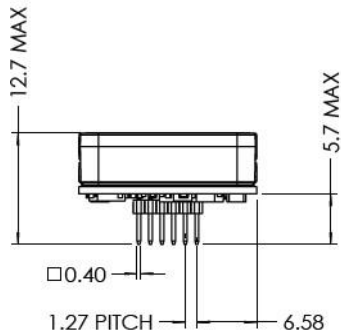
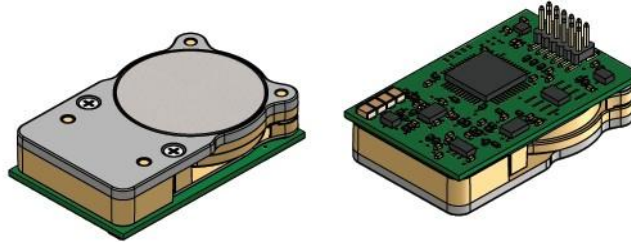
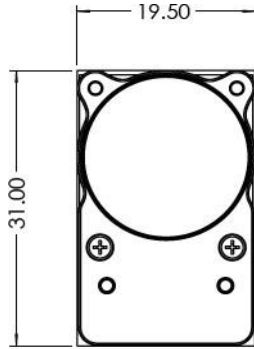

**Ultra Low Power CO<sub>2</sub> Sensor with T & R/H**

**PINOUT COZIR-LP2-2 and COZIR-BLINK-2**

PIN	NAME	TYPE	DESCRIPTION
1	GND	Supply	Sensor ground
2	VDD	Supply	Sensor supply voltage
3	Rx_In	Digital Input	UART Receive Input
4	Tx_Out	Digital Output	UART Transmit Output
5	NC	Unused	
6	READY	Digital Output	Data ready pin. Pulsed high when data ready
7	ALARM	Digital Output	Alarm Output
8	PWM	Digital Output	PWM Output
9	ENABLE	Digital Input	Sensor Power on Enable pin. - Power on – High - Power off – Low If unused, connect to VDD
10	I2C_ENABLE	Digital Input	Set low for I <sup>2</sup> C interface mode. Leave floating to select UART interface mode. Pin status detected at power on.
11	I2C_SCL	Digital Input	I <sup>2</sup> C serial clock input. Open drain, external 4.7kΩ resistor pulled high to VDD required
12	I2C_SDA	Digital Input/Output	I <sup>2</sup> C serial data input/output. Open drain, external 4.7kΩ resistor pulled high to VDD required

**Ultra Low Power CO<sub>2</sub> Sensor with T & R/H**

**PACKAGE DRAWINGS COZIR-LP3-2 and COZIR-BLINK-N-2**

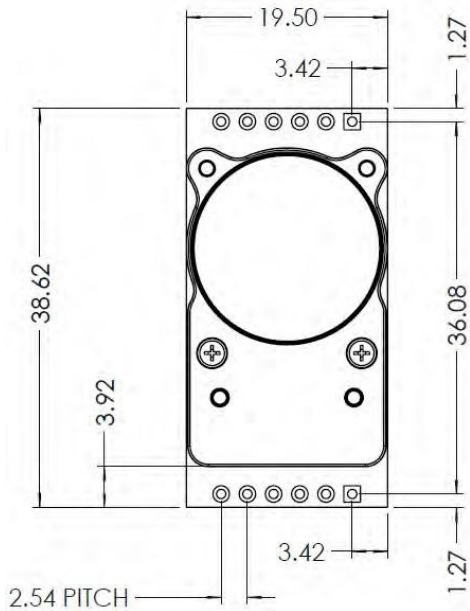

0.9mm HOLE WITH 1.6mm PAD

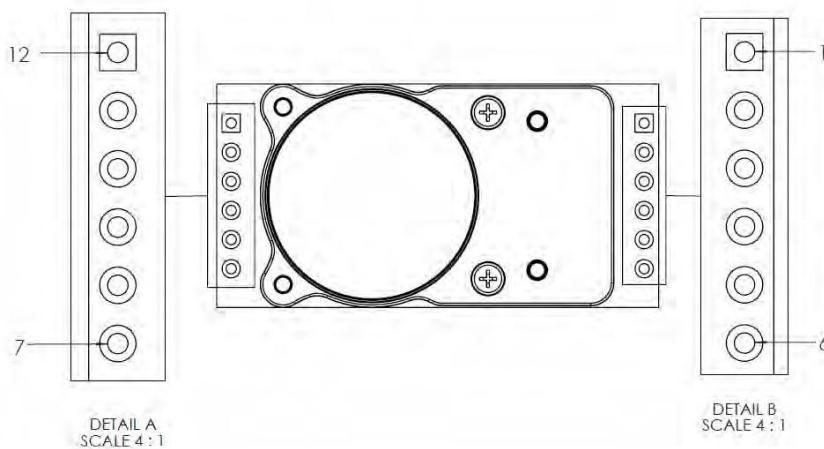
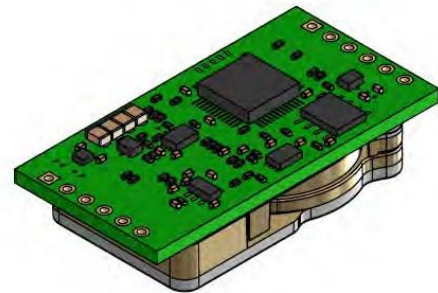
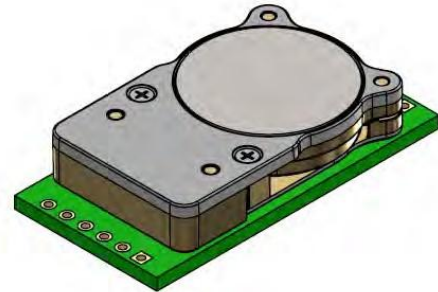
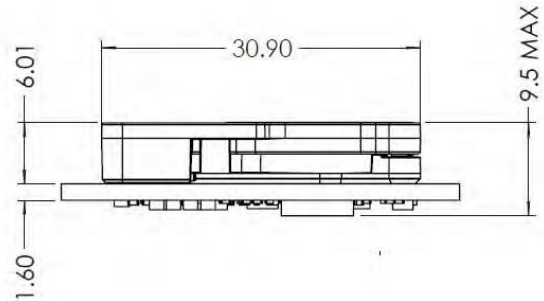
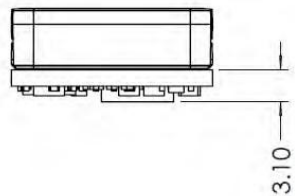

**Ultra Low Power CO<sub>2</sub> Sensor with T & R/H**

**PINOUT COZIR-LP3-2 and COZIR-BLINK-N-2**

PIN	NAME	TYPE	DESCRIPTION
1	GND	Supply	Sensor ground
2	VDD	Supply	Sensor supply voltage
3	NC	Unused	Do not connect (For internal use only)
4	PWR_ON	Digital Input	Sensor Power on Enable pin. - Power on – High - Power off – Low If unused, connect to VDD
5	ALARM	Digital Output	Alarm Output
6	READY	Digital Output	Data ready pin. Pulsed high when data ready
7	PWM	Digital Output	PWM Output
8	I2C_ENABLE	Digital Input	Set low for I <sup>2</sup> C interface mode. Leave floating to select UART interface mode. Pin status detected at power on.
9	I2C_SCL	Digital Input	I <sup>2</sup> C serial clock input. Open drain, external 4.7kΩ resistor pulled high to VDD required
10	I2C_SDA	Digital Input/Output	I <sup>2</sup> C serial data input/output. Open drain, external 4.7kΩ resistor pulled high to VDD required
11	Tx_Out	Digital Output	UART Transmit Output
12	Rx_In	Digital Input	UART Receive Input

**Ultra Low Power CO<sub>2</sub> Sensor with T & R/H**

**ABSOLUTE MAXIMUM RATINGS**

Absolute Maximum Ratings are stress ratings only. Permanent damage to the CozIR®-LP series may be caused by continuously operating at or beyond these limits. The CozIR®-LP series functional operating limits and guaranteed performance specifications are given at the test conditions specified.



ESD Sensitive Device. This sensor uses ESD sensitive components. It is therefore generically susceptible to damage from excessive static voltages. Proper ESD precautions must be taken during handling and storage of this device.

CONDITION	MIN	MAX
Supply Voltages	-0.3V	+6.0V
Voltage Range Digital Inputs	GND -0.3V	5V
Operating Temperature Range (Ta)	0°C	+50°C
Storage Temperature Range	-40°C	+70°C
Humidity Range (RH), non-condensing	0	95%
Operating Pressure Range – output compensated	756 mb	1050mb

**RECOMMENDED OPERATING CONDITIONS**

PARAMETER	SYMBOL	MIN	TYP	MAX	UNIT
Supply	VDD	3.25	3.3	5.5	V
Ground	GND		0		V

**Ultra Low Power CO<sub>2</sub> Sensor with T & R/H**

**PERFORMANCE CHARACTERISTICS**

**Test Conditions Unless Otherwise Specified**

VDD = 3.3V, GND = 0V. CO<sub>2</sub> = 450ppm, RH = 0% non-condensing, T= 25°C, Pressure = 1013mbar

PARAMETER	TEST CONDITIONS	MIN	TYP	MAX	UNIT
CO <sub>2</sub> measurement range		0		2,000	ppm
		0		5,000	ppm
		0		10,000	ppm
Accuracy	@25°C		±(30 +3%rdg)	±(45 +3%rdg)	ppm
	0°C to +50°C, after zeroing @25°C		±(30 +3%rdg)		ppm
Time to Valid Measurement After Power-On	First value from sensor		0.8 3.2 ( BLINK )		secs
Response Time	From 0ppm to T90, default settings, limited by diffusion through membrane window	35	40	45	secs
Repeatability			±(30 +3%rdg)		%
Pressure Dependence <sup>1,2</sup>	Per mbar deviation from 1013mbar, 950-1050mbar		0.14		%
Current Consumption	Peak current when sampling, 16 pulses per reading			35	mA
	Average current when sampling, 16 pulses per reading	1.3		1.5	mA
	Peak at turn-on	80		100	mA
	SLEEP Mode		0.01 BLINK – 0 when off		mA

**Notes**

1. CO<sub>2</sub> measurement error based on changes to barometric pressure from nominal 1013mbar
2. Corrected value (Z) valid only for <1% CO<sub>2</sub> gas concentrations and specified barometric pressure range

**Ultra Low Power CO<sub>2</sub> Sensor with T & R/H**

**ELECTRICAL CHARACTERISTICS**

PARAMETER	TEST CONDITIONS	MIN	TYP	MAX	UNIT
Input HIGH Level		1.8			V
Input LOW Level				1.0	V
Output HIGH Level	I <sub>OH</sub> = +1mA	2.6			V
Output LOW Level	I <sub>OL</sub> = -1mA			0.4	V

SETTING	TEST CONDITIONS	VDD		Total Power
		V	I (mA)	mW
OFF and BLINK	No power applied		0	0
Active, SLEEP mode, no measurement		3.3	0.01	0.03
Active, taking measurements	Default settings	3.3	1.3 - 1.5	4.3 - 5.0

## **Ultra Low Power CO<sub>2</sub> Sensor with T & R/H**

### **METHOD OF OPERATION – COZIR-LP1-2, COZIR-LP2-2, COZIR-LP3-2**

The CozIR®-LP1-2, LP2-2, LP3-2 products are designed for applications where power is often at a premium. After power is applied to any of the CozIR®- LP series, the sensor will automatically start to take and send CO<sub>2</sub> measurements using the Mode 1 default settings at 2Hz.

The sensor will return the previous CO<sub>2</sub> measurement results if the user requests more frequent measurements.

The CozIR®-LP series has 3 potential modes of operation:

#### **MODE 0 COMMAND MODE**

In this mode, the sensor is in a SLEEP mode, waiting for commands. No measurements are made. All commands that report measurements or alter the zero-point settings are disabled in Mode 0. Mode 0 is NOT retained after power cycling.

#### **MODE 1 STREAMING MODE**

This is the factory default setting. Commands are processed when received. Continuous communication to the sensor will slow/halt the measurement process.

#### **MODE 2 POLLING MODE**

In polling mode, the sensor only reports readings when requested. The sensor will continue to take measurements in the background, but the output stream is suppressed until data is requested. The sensor will always power up in streaming or polling mode, whichever mode was used before the power cycle.

## Ultra Low Power CO<sub>2</sub> Sensor with T & R/H

### BLINK MODE

The CozIR®-Blink-2 is designed for ultra-low power applications where power is often at a premium. CozIR®-Blink is designed to be power cycled. When the sensor is switched on, a measurement is automatically initiated. Data can be read out once the READY pin is pulsed high. The sensor can then be subsequently switched off, saving power.

### DATA READY

After power is applied to the CozIR®-Blink-2, the sensor will automatically start to take CO<sub>2</sub> measurements using the configured settings. Once the READY flag has been pulsed high, the sensor will respond to requests for CO<sub>2</sub> data. The control interface is available approximately 14ms after the falling edge of a valid READY pulse.

PARAMETER	SYMBOL	MIN	TYP	MAX	UNIT
READY Data Valid from Power On	t1	0.5	3.5		s
READY High Pulse-Width	t2		1.0		ms
READY Low from Power On	t3			100	ms
Control Interface Setup Time	t4	14			ms
Control Interface Active to Safe Shutdown Time <sup>1</sup>	t5	228	5.8		ms

## Ultra Low Power CO<sub>2</sub> Sensor with T & R/H

### MEASUREMENT CYCLE

The measurement cycle is the same in either UART or I<sup>2</sup>C connection mode but the method of obtaining the CO<sub>2</sub> value is different.

- Apply power to the Sensor.
- The sensor will automatically start taking measurements. The sensor takes a measurement using the configured number of pulses (*npulse*). The default setting is 16
- The measurement time is approximately 200ms + (200ms x *npulse*)
- The typical measurement time using the default setting *npulse* of 16 is 3400ms
- The data READY flag is set low within 100ms of power on.
- When the measurement is complete, the data READY flag will be pulsed high for approximately 1.0ms with data available approximately 14ms after the falling edge of the READY flag.
- ***In UART mode, the CO<sub>2</sub> reading can only be read once by the user.*** The sensor will not report the CO<sub>2</sub> reading again after this point and a new measurement will not be taken until the sensor is power cycled. After the initial request, the sensor will respond with an invalid command if a CO<sub>2</sub> reading is requested again.
- In I<sup>2</sup>C mode, the user should wait for 14ms after the READY flag is pulsed high and the appropriate register can be read. In this mode, the register reading can be read repeatedly but the value will not change until the sensor is power cycled again.
- After the measurement is sent to or read by the host (depending on UART or I<sup>2</sup>C mode), the sensor will go into SLEEP mode, and will take no further measurements until the power is cycled again.
- During SLEEP mode, the sensor will respond to commands, and can be re-configured but no further measurements will be taken.
- If a sensor register value is changed, sufficient time must be allowed to ensure the new value is safely written to memory.
- Note, if the sensor does an auto-zero, it will extend the measurement time by ~2s but is done before the READY flag is set high.
- A new measurement cycle will only start the next time the sensor is power cycled.
- The number of pulses (*npulse*) can be set and read by the use

## Ultra Low Power CO<sub>2</sub> Sensor with T & R/H

### DIGITAL FILTER

Noise coming from the sampling process is removed using a proprietary lowpass filter. The digital filter setting can be varied, allowing the user to reduce measurement noise at the expense of the measurement response time.

The ideal digital filter setting is application specific and is normally a balance between CO<sub>2</sub> reading accuracy and response time. The CozIR®-LP series sensors can also be programmed to output the raw unfiltered CO<sub>2</sub> measurement data. This data can be post processed using alternative filter algorithms by the customer.

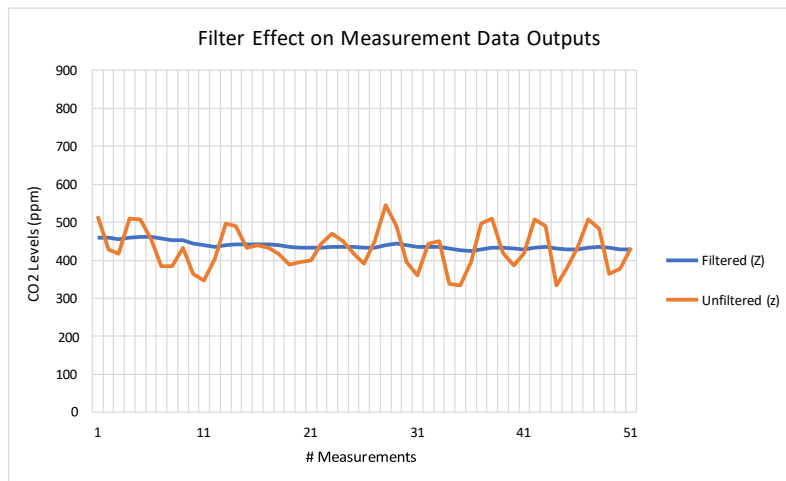

The graph above shows the effects of the filter on the CO<sub>2</sub> measurement data (Z). The unfiltered output (z) is shown in orange and the filtered output (Z) shown in blue.

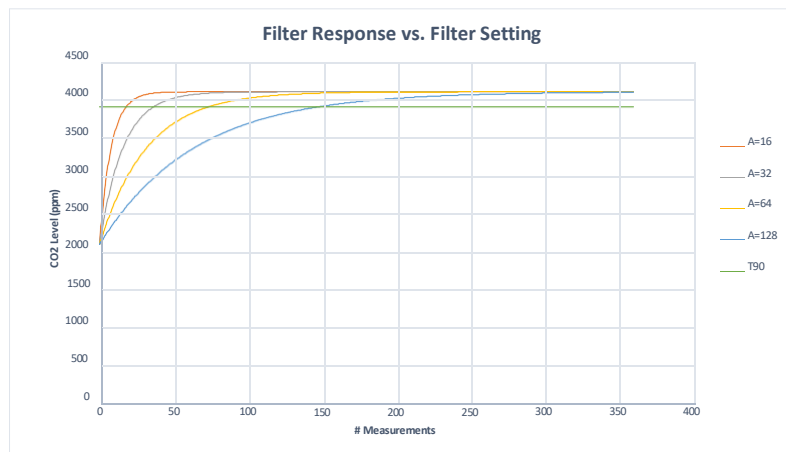

The graph above shows the effect of the filter on response times. Increasing the filter setting increases the measurement output response time.

## **Ultra Low Power CO<sub>2</sub> Sensor with T & R/H**

### **ZEROING**

**Whilst sensors are calibrated for life at the manufacturing stage, they will be subject to zeroing changes in transit and in use. This does NOT affect the calibration. Hence all sensors need to be zeroed before first use and the customers interfaces must ensure the sensor is zeroed periodically.**

### **ZERO POINT SETTING**

In all cases, the best zero is obtained when the gas concentration is stable, and the sensor is at a stabilised temperature. Zero-point settings are not cumulative and only the latest zero-point setting is effective. For example, there is no benefit in zeroing in nitrogen, and then zeroing in a calibration gas. The sensor will store only the latest zero point regardless of what method is used. There are a several different methods available to the user to set the zero point of the sensor:

### **ZERO IN A KNOWN GAS CONCENTRATION**

Place the sensor in a known gas concentration and allow at least 5 minutes for the sensor temperature to stabilise, and for the gas to be fully diffused into the sensor.

Power up the sensor and wait >5s for full stabilisation

Write the known concentration level to the sensor, then initiate the Zero in a Known Gas calibration method. The concentration must be in ppm.

### **ZERO IN NITROGEN**

Place the sensor in the nitrogen gas and allow at least 5 minutes for the sensor temperature to stabilise, and for the gas to be fully diffused into the sensor.

Power up the sensor and wait >5 s for full stabilisation

Initiate the Zero in Nitrogen command. The sensor is zeroed assuming a 0ppm CO<sub>2</sub> environment.

### **ZERO IN FRESH AIR**

If there is no calibration gas or nitrogen available, the sensor zero point can be set in fresh air. Ambient CO<sub>2</sub> concentration in fresh air is typically 400ppm. This level is programmable over a range from 0ppm to the full scale of the sensor.

Place the sensor in a fresh air environment and allow at least 5 minutes for the sensor temperature to stabilise, and for the fresh air to be fully diffused into the sensor.

Power up the sensor and wait >5 s for full stabilisation

The user can initiate a Zero in Fresh Air zero cycle. The sensor can use the default fresh air CO<sub>2</sub> concentration value (400ppm), or the user can write a different fresh air value to the sensor if desired.

## Ultra Low Power CO<sub>2</sub> Sensor with T & R/H

### ZERO POINT ADJUSTMENT

If the CO<sub>2</sub> concentration and the sensor reported concentrations are known, the zero point can be adjusted using the known concentration to fine tune the zero point. For example, if the sensor has been in an environment that has been exposed to outside air, and the sensor reading is known at that time, the zero point can be fine-tuned to correct the reading. This is typically used to implement automated zeroing routines.

### AUTO-ZERO FUNCTION

The sensor has a built-in auto-zeroing function. To function correctly, the sensor must be exposed to typical background levels (400-450ppm) at least once during the auto-zero period. For example, many buildings will drop quickly to background CO<sub>2</sub> levels when unoccupied overnight or at weekends. The auto-zero function uses the information gathered during these periods to re-zero.

The sensor will reset the 'zero' level every time it does an auto-zero.

Auto-zero is ENABLED by default. If the sensor is powered down, the auto-zero period settings are reset to the default value except in BLINK mode.

BLINK mode works on a number of power cycles and therefore does not lose its value when power is removed from the sensor.

The auto-zero function works in the same way as the **ZERO IN FRESH AIR** command. Auto-zeroing is enabled by default. It is enabled to operate automatically but can be disabled or it can be forced. The user can also independently adjust the CO<sub>2</sub> level used for auto-zeroing. Typically, it is set to the same value as the **ZERO IN FRESH AIR** value, but it can also be set at a different level if desired.

### AUTO-ZERO INTERVALS

The auto-zero period can be programmed by the user. The sensor can be programmed to undertake an initial auto-zero after power-on. Thereafter, the auto-zero period can be set independently of the start-up auto-zero time. Note, the auto-zero timer is reset if the sensor is powered down.

Auto-Zero Period	Minimum Value	Maximum Value	Default Value	Resolution
<b>COZIR-LP1-2, LP2-2, LP3-2</b>				
Initial Auto-Zero	0.1 days	37.9 days	1 days	0.1 day
On-Going Auto-Zero	0.1 days	37.9 days	8 days	0.1 day
<b>COZIR-BLINK-2 and BLINK-N-2</b>				
Power Cycles	100	65535	5000	0.1

### AUTO-ZERO LEVEL

The background concentration will depend on sensor location. Ambient levels are typically in the range of 400ppm-450ppm. The factory default is set to 400ppm. The user can change the background ambient level used for auto-zeroing. The value is stored in the sensor.

## **Ultra Low Power CO<sub>2</sub> Sensor with T & R/H**

### **ALTITUDE COMPENSATION**

NDIR gas sensors detect the concentration of gas by measuring the degree of light absorption by the gas analyte. The degree of light absorption is then converted into a concentration reported by the sensor. The absorption process is pressure dependent, and a change in pressure will cause a change in the reported gas concentration.

As the pressure increases, the reported gas concentration also increases. As the pressure decreases, the reported concentration decreases.

GSS sensors are factory calibrated at 1013 mbar. The reading will vary by approximately 0.14% of reading for each mbar change in barometric pressure.

If the sensor is installed at an elevated altitude, the mean barometric pressure will be lower than 1013mbar. It is possible to configure the sensor to correct for this effect, by setting the altitude compensation value as part of the initial set up process. This will apply a permanent correction to the output of the sensor, depending on the altitude value input.

The sensor will take pressure inputs directly in mb using the [ command to set the atmospheric pressure between readings if required. In automated control systems this value can be updated as required from a local pressure sensing system. It can be read back using the ] command.

Compensation linearity can be provided by GSS engineers if required

## **Ultra Low Power CO<sub>2</sub> Sensor with T & R/H**

### **CONTROL INTERFACE**

The CozIR®-LP1-2, LP2-2, LP3-2, BLINK-2 and BLINK-N-2 can be simply controlled by writing and reading from the sensor via its UART interface.

Additionally, CozIR®-LP2-2, LP3-2, BLINK-2 and BLINK-N-2 can be controlled via a standard I2C interface.

The interfaces will be described separately on the following pages:

## Ultra Low Power CO<sub>2</sub> Sensor with T & R/H

### UART MODE

#### CONTROL INTERFACE TIMING

PARAMETER	MIN	TYP	MAX	UNIT
Baud Rate (Fixed)		9,600 38400 ( BLINK )		Bits/s
Data Bits		8		
Parity		None		
Stop Bits		1		
Hardware Flow Control		None		

#### UART COMMAND PROTOCOL

All UART commands must be terminated with a carriage return and line feed <CR><LF>, hex 0x0D 0x0A. In this document, this is shown as '\r\n'. UART commands that take a parameter always have a space between the letter and the parameter. The sensor will respond with a '?' if a command is not recognised.

All command communications are in ASCII and are terminated by carriage return, line feed (0x0D 0x0A). This document uses the protocol "\r\n" to indicate the carriage return line feed. All responses from the sensor, including measurements, have a leading space (ASCII character 32).

The character '#' represents an ASCII representation of a numeric character (0-9). Note there is always a space between the first letter and any parameter. For example, the X command reads "X space 2000 carriage return line feed".

**Ultra Low Power CO<sub>2</sub> Sensor with T & R/H**

**UART INTERFACE SUMMARY**

Syntax	Use	Example	Response	Comments	Range	Default	Applies to
A ###\r\n	Set value of the digital filter	A 128\r\n	A 00128\r\n	See <b>“Digital Filter”</b>	0-255	16	All except BLINK
A ###\r\n	Sets the value of nPulse	A 16\r\n	A 00016\r\n	See <b>“nPulse”</b>	1-32	16	BLINK
a\r\n	Return the value of the digital filter	a\r\n	a 00128\r\n	See <b>“Digital Filter”</b>	0-255		All
a\r\n	Reads the value of nPulse	a\r\n	a 00016\r\n	See <b>“nPulse”</b>	1-32		BLINK
c\r\n	Reports sensor operating hours	c\r\n	c 00085\r\n		99999 max		All
F #####\r\n	Fine Tune the zero point	F 410 400\r\n	F 33000\r\n	See <b>“Zero Point Setting”</b>			All
G\r\n	Zero-point setting using fresh air	G\r\n	G 33000\r\n	See <b>“Zero Point Setting”</b>		400 ppm	All
i \r\n	Self-test error condition	i\r\n	i 00085\r\n = no error i 000170\r\n = error		00085-00170		All
J ###\r\n	PWM control byte	J ###\r\n	J #####\r\n	See <b>“PWM Control”</b>			All except LP1
J\r\n	Read PWM control byte	j\r\n	j #####\r\n	See <b>“PWM Control”</b>			All except LP1
K #\r\n	Switches the sensor between different modes	K 1\r\n	K 00001\r\n		0,1,2	1	All
M ###\r\n	Sets the number of measurement data types output by the sensor	M 6\r\n	M 00006\r\n	See <b>“Measurement Data Outputs”</b>			All
P 8 ###\r\n P 9 #\r\n	Sets value of CO <sub>2</sub> background concentration in ppm for auto-zeroing	P 8 1\r\n P 9 144\r\n	P 00008 00001\r\n P 00009 00144\r\n	Two-byte value, P 8 = MSB P 9 = LSB  400ppm in the example			All
P 10 ###\r\n P 11 #\r\n	Sets value of CO <sub>2</sub> background concentration in ppm used for zero- point setting in fresh air.	P 10 1\r\n P 11 144\r\n	P 00010 00001\r\n P 00011 00144\r\n	Two-byte value, P 10 = MSB P 11 = LSB  400ppm in the example			All

**Ultra Low Power CO<sub>2</sub> Sensor with T & R/H**

Q\r\n	Reports the latest measurement data types, as defined by 'M'	Q\r\n	Z 00010\r\n				All
t#\r\n	Switches the temperature and humidity sensor on and off	t 1\r\n	t 00001	Default T+H is 0.  Example sets T to on ( 1 )			Sensors fitted with T+H option
T\r\n	Reports the current sensor temperature	T\r\n	T 01255	See " <b>Temperature Measurements</b> "			Sensors fitted with T+H option
H	Reports the current sensor humidity in RH %	H\r\n	H 00356	See " <b>Humidity Measurements</b> "			Sensors fitted with T+H option
U\r\n	Zero-point setting using nitrogen	U\r\n	U 33000\r\n	See " <b>Zero Point Setting</b> "			All
u #####\r\n	Manual setting of the zero point.	u 32997\r\n	u 32997\r\n	See " <b>Zero Point Setting</b> "			All
V #####	Set alarm value	V 15000\r\n	V 15000\r\n	See " <b>Alarm Value</b> "			All except LP1
v\r\n	Read alarm value	v\r\n	v 15000\r\n	See " <b>Alarm Value</b> "			All except LP1
X #####\r\n	Zero-point setting using a known gas calibration	X 2000\r\n	X 32997\r\n	See " <b>Zero Point Setting</b> "  Example shows setting to 2000 ppm			All
Y\r\n	Return firmware version and sensor serial number	Y\r\n	Returns <u>two</u> lines	Example layout – LPX2nnn			All
Z\r\n	Return the most recent filtered CO <sub>2</sub> 2 measurement in ppm	Z\r\n	Z 00521\r\n				All
z\r\n	Return the most recent unfiltered CO <sub>2</sub>	z\r\n	Z 00521\r\n				All
@ ##\r\n	Sets the timing for initial and interval auto-zero periods	@ 1.0 8.0\r\n	@ 1.0 8.0\r\n	See " <b>Auto-zero setting</b> " for details  Example is an initial zero at 1 day and subsequent at 8 day intervals.		1.0 8.0	All except BLINK
@\r\n	Returns the Auto-zero configuration	@ 1.0 8.0\r\n	@ 1.0 8.0\r\n	See " <b>Auto-zero setting</b> " for details		1.0 8.0	All except BLINK
@ 0\r\n	Switch Auto-zeroing on or off	@ 0\r\n	@ 0\r\n	See " <b>Auto-zero setting</b> " for details Example shows auto zeroing being switched off		00001	All

**Ultra Low Power CO<sub>2</sub> Sensor with T & R/H**

@ #####\r\n	Sets power cycle auto-zero count	@ 5000\r\n	@ 05000\r\n	See " <b>Auto-Zero Function</b> " for details  Example shows 5000 power cycles	5000		BLINK
.\r\n	Returns the scaling factor multiplier required to convert the Z or z output to ppm	.\r\n	. 00001\r\n	Multiply by 1 in the example	1-99999	1	All
[ #####\r\n	Set pressure value in mbar	[ 997\r\n	[ 00997\r\n	See " <b>Altitude Pressure Compensation</b> "		1013	All
] #####\r\n	Read pressure value in mbar	]\r\n	] 00997\r\n	See " <b>Altitude Pressure Compensation</b> "		1013	All

## Ultra Low Power CO<sub>2</sub> Sensor with T & R/H

### SETTING AUTO-ZERO INTERVALS

#### Non BLINK

Both the initial interval and regular interval are given in days. Both must be entered with a decimal point and one figure after the decimal point. In the above example, the auto-zeroing interval is set to 8 days, and the initial interval set to 1 day.

The CozIR®-LP series has auto-zero ENABLED by default. The default values are an initial interval of 1.0 day and an on-going interval of 8.0 days.

- To set auto-zero OFF, send @ 0\r\n
- To set auto-zero ON, send @ #.#.#\r\n (integer numbers for initial period and regular period)
- To determine the auto-zeroing configuration, send @\r\n
- If the auto-zero function is OFF, @\r\n will return 0.
- If the auto-zero is ON, @\r\n will return 1.0 8.0 (for the default values).

#### BLINK

A BLINK sensor uses a simple power cycle count to perform an auto zero operation

The CozIR®-LP BLINK has auto-zero ENABLED by default. The default value is 5000 power cycles.

- To set auto-zero OFF, send @ 0\r\n
- To set auto-zero ON, send @ #####\r\n where ##### is the number of power cycles before Auto Zero
- To determine the auto-zeroing configuration, send @\r\n
- If the auto-zero function is OFF, @\r\n will return 0.
- If the auto-zero is ON, @\r\n will return @ #####(the programmed value )

## Ultra Low Power CO<sub>2</sub> Sensor with T & R/H

### SETTING CO<sub>2</sub> LEVEL TO BE USED IN AUTO ZEROING

<b>Description</b>	Sets the value of CO <sub>2</sub> in ppm used for auto-zeroing. Input value is scaled by CO <sub>2</sub> value multiplier, see '.' command.
<b>Syntax</b>	ASCII character 'P', SPACE, then 8, SPACE, then MSB terminated by 0x0D 0x0A (CR & LF)  ASCII character 'P' then a space, then 9, then a space, then LSB terminated by 0x0D 0x0A (CR & LF)
<b>Example</b>	P 8 0\r\n P 9 40\r\n
<b>Response</b>	p 8 0\r\n p 9 40\r\n

The value is entered as a two-byte word, MSB first. MSB

= Integer (Concentration/256)

LSB = Concentration – (256\*MSB)

In the above example, target CO<sub>2</sub> background concentration is 400ppm.

MSB = Integer (400/256) = 1

LSB = 400 – 256 = 144

*The default value is 400ppm.*

### SETTING CO<sub>2</sub> LEVEL TO BE USED FOR ZERO POINT SETTING

<b>Description</b>	Sets value of CO <sub>2</sub> in ppm for zero-point setting in fresh air.
<b>Syntax</b>	ASCII character 'P' then a space, then 10, then a space, then MSB terminated by 0x0D 0x0A (CR & LF)  ASCII character 'P' then a space, then 11, then a space, then LSB terminated by 0x0D 0x0A (CR & LF)
<b>Example</b>	P 10 7\r\n P 11 208\r\n
<b>Response</b>	P 00010 00007\r\n P 00011 00208\r\n

MSB = Integer (Concentration/256)

LSB = Concentration – (256\*MSB)

In the above example, target zero-point CO<sub>2</sub> concentration is 2000ppm.

MSB = Integer (2000/256) = 7

LSB = 2000 – (256\*MSB) = 208

*The default value is 400ppm.*

## Ultra Low Power CO<sub>2</sub> Sensor with T & R/H

### I<sup>2</sup>C MODE

The CozIR®-LP2-2, LP3-2 and BLINK-2 variants can be controlled by writing to registers through a serial control interface.

The CozIR®-LP series I2C interface supports software control via a 2-wire serial bus. Many devices can be controlled by the same bus, and each device has a unique 7-bit address. The CozIR®-LP I2C interface operates as a slave only device.

The controller indicates the start of data transfer with a high to low transition on I2C\_SDA while I2C\_SCL remains high (I<sup>2</sup>C Start condition). This indicates that a device address will follow. All devices on the 2-wire bus respond to the start condition and shift in the next eight bits on I2C\_SDA (7-bit address + Read/Write bit, MSB first). If the device address received matches the address of the CozIR®-LP I2C interface and the R/W bit is '0', indicating a write, then the CozIR®-LP2 responds by pulling I2C\_SDA low on the next clock pulse (ACK). If the address is not recognised or the R/W bit is '1', the CozIR®-LP I2C returns to the idle condition and waits for a new start condition and valid address.

The CozIR®-LP I2C acknowledges the correct address by pulling I2C\_SDA low for one clock pulse. The master then sends the address of the register it wishes to read from or write to. Data is either read from or written to in 1 - 4 bytes, most significant byte (MSB) first.

The transfer of data is complete when there is a low to high transition on I2C\_SDA while I2C\_SCL is high. After receiving a complete address and data sequence the CozIR®-LP I2C returns to the idle state and waits for another start condition. If a start or stop condition is detected out of sequence at any point during data transfer (i.e. I2C\_SDA changes while I2C\_SCL is high), the device jumps to the idle condition.

***The CozIR®-LP2 device address is 0x41 and cannot be changed by the user.***

I2C can be selected by using the I2C\_ENABLE pin. The state of the I2C\_ENABLE pin is sampled at power up only and cannot be changed after power up. Setting the I2C\_ENABLE pin low puts the CozIR®-LP2 into I<sup>2</sup>C interface mode.

### INTERFACE TIMING

PARAMETER	SYMBOL	MIN	TYP	MAX	UNIT
I2C_SCL Frequency		0		100	kHz
I2C_SCL Low Pulse-Width	t <sub>1</sub>	4.7			us
I2C_SCL High Pulse-Width	t <sub>2</sub>	4.0			us
Hold Time (Start Condition)	t <sub>3</sub>	4.0			us
Setup Time (Start Condition)	t <sub>4</sub>	4.7			us
Data Setup Time	t <sub>5</sub>	250			ns
I2C_SDA, I2C_SCL Rise Time	t <sub>6</sub>			1000	ns
I2C_SDA, I2C_SCL Fall Time	t <sub>7</sub>			300	ns
Setup Time (Stop Condition)	t <sub>8</sub>	4.0			us
Data Hold Time	t <sub>9</sub>	0		5.0	us
Capacitive load for each bus line	-			400	pF

**Ultra Low Power CO<sub>2</sub> Sensor with T & R/H**

**I<sup>2</sup>C REGISTER MAP**

REGISTER	DESCRIPTION	DEFAULT	RANGE	SIZE (BYTES)	READ/WRITE	APPLIES TO
R0 (0x00)	Measurement Control	1	0-1	1	READ/WRITE	All
R2 (0x02)	CO <sub>2</sub> Level (ppm) with Status Byte	N/A	0 – 65535	2(3)	READ only	All
R4 (0x04)	Digital Filter Setting	16	1 - 255	1	READ/WRITE*	All Except BLINK
R5 (0x05)	Sensor Control Settings			1	WRITE only	All
R6 (0x06)	Auto-Zero Initial Interval Period	12096	0 - 65535	2	READ/WRITE	All Except BLINK
R8 (0x08)	Auto-Zero Interval Period	13824	0 - 65535	2	READ/WRITE	All Except BLINK
R12 (0x0C)	Auto-Zero Target Level	400ppm	0 to full scale	2	READ/WRITE	All
R18 (0x12)	Target value for CO <sub>2</sub> in fresh air (in ppm)	400ppm	0 to full scale	2	READ/WRITE	All
R20 (0x14)	Known CO <sub>2</sub> Concentration (in ppm)		0 to full scale	2	READ/WRITE	All
R26 (0x1A)	Auto-Zero Cycles	5000	50 – 39268	2	READ/WRITE*	BLINK ONLY
R32 (0x20)	Reads Temperature	01000 (R140=0)	01000 if off -40 to 125 deg C	2	READ	All if T+H option Specified
R34 (0x22)	Reads Temperature	00000 (R140=0)	0 if off 0 to 100 % RH	2	READ	All if T+H option Specified
R38 (0x26)	Serial Number	N/A		4	READ only	All
R42 (0x2A)	nPulse (1 -32)	4296	456 - 8392	2	READ/WRITE*	BLINK ONLY
R44 (0x2C)	Alarm Level	0	0-20000	2	READ/WRITE	All Except LP1
R46 (0x2E)	PWM control	0	0-255	1	READ/WRITE	All Except LP1
R52 (0x34)	Unfiltered CO <sub>2</sub> level ( ppm )	N/A	0-65535	2	READ	All
R78 (0x4E)	Auto-Zero Control	2		1	READ/WRITE*	All
R80 (0x50)	Self Test	00085		1	READ	All
R90 (0x5A)	Reports total number of hours	N/A			READ	All
R118 (0x76)	Altitude pressure in mbar	1013	697 – 1050	2	READ/WRITE	All
R140 (0x8c)	Sets T+H sensor on and off	0	0-1	1	WRITE	All if T+H option Specified

\* Indicates a sensor zero should be performed after the default values are changed.

## Ultra Low Power CO<sub>2</sub> Sensor with T & R/H

### MEASUREMENT CONTROL – R0

This allows CO<sub>2</sub> Measurement to be switched on or off. Write 00000010 for on, 00000000 for off. If measurements are switched off, all zero setting commands are automatically disabled.

### CO<sub>2</sub> LEVEL MEASUREMENT VALUE WITH STATUS BYTE – R2

The measured CO<sub>2</sub> level is read from Register R2. The first two 8-bit bytes are CO<sub>2</sub> measurement data, MSB first. The value is CO<sub>2</sub> level in ppm. Byte 3 can be read as the global self-test error status value, or the status can be read from register 80.

### CO<sub>2</sub> LEVEL MEASUREMENT VALUE ONLY – R52

The measured CO<sub>2</sub> level, 2 bytes, MSB first. The value is CO<sub>2</sub> level in ppm

### AUTO-ZERO INITIAL INTERVAL PERIOD – R6

Sets the auto-zero initial interval count period. Each count is 0.5s.  
The default initial auto-zero period value 12096, equivalent to 7 days.

### AUTO-ZERO INTERVAL PERIOD – R8

Sets the auto-zero interval period. Each count is 0.5 s  
The default auto-zero period value 13824, equivalent to 8 days.

### AUTO-ZERO TARGET VALUE – R12

Sets the target value for CO<sub>2</sub> level when doing an auto-zeroing  
The user can independently set the target value for CO<sub>2</sub> used for an auto-zero event. The default is 400ppm.

### ZERO IN FRESH AIR

Target value for CO<sub>2</sub> in fresh air  
The target value for CO<sub>2</sub> in fresh air is stored in register 18. The default is 400ppm.

### CONTROL VALUE – R20

Stores the new target value. All CO<sub>2</sub> values are in ppm. Number is a two-byte value, MSB first.

**Ultra Low Power CO<sub>2</sub> Sensor with T & R/H**

**ZERO CONTROL – R5**

BIT	LABEL	DESCRIPTION	DEFAULT	READ/WRITE
0	Air Zero	Sets the zero point assuming the sensor is in 400ppm CO <sub>2</sub> . If using a different CO <sub>2</sub> value, write the CO <sub>2</sub> level into Register 18 prior to initiating the zero process.  00000000: No Zero 00000001: Zero	N/A	Write
1	Nitrogen Zero	Sets the zero point assuming the sensor is in 100% nitrogen.  00000000: No Zero 00000010: Zero in Nitrogen	N/A	Write
2	X Zero	Sets the zero point with the sensor in a known concentration of CO <sub>2</sub> .  Write the target ppm concentration into Register 20 prior to initiating the zero process.  00000000: No X Zero 00000010: X Zero	N/A	Write

The control register 5 enables the user to transfer the value stored in register 18 or register 20 into the selected location in the sensor. Once the new target value has been written into register 18 or register 20, then write to register R5 to complete the data transfer.

Once the new data has been written to memory, register 5 is cleared

## Ultra Low Power CO<sub>2</sub> Sensor with T & R/H

### SERIAL NUMBER – R38

Unique sensor serial number, 32-digit code

### ALARM OUTPUT

The sensor comes with a CO<sub>2</sub> level alarm function. The ALARM pin goes high if the detected CO<sub>2</sub> level exceeds the alarm threshold value. The alarm threshold detection can be enabled or disabled. It is disabled by default.

If enabled, the alarm is triggered when the measured CO<sub>2</sub> reading exceeds the alarm threshold value. The alarm is cleared if the measured CO<sub>2</sub> reading falls below 80% of the alarm threshold value.

The alarm is off if the CO<sub>2</sub> level alarm level is set to zero. The default setting is zero.

The alarm value is retained after the sensor is power cycled.

### BUILT-IN SELF TEST

The sensor has a built-in test function that automatically checks if it is operating correctly at power-on and during a measurement cycle. The sensor will store an error condition if any of the following are triggered.

ERROR FLAG	ERROR CONDITION
Sensor Lifetime	If the total power-on time exceeds 20000 hours
LED optical output value	If LED output is out of range
CO <sub>2</sub> out of range	If the temperature compensated CO <sub>2</sub> value is out of range
ADC input value	If the ADC input signal is out of the expected range

The sensor will return a self-test decimal value of 85 if operation is nominal or 170 if any of the error conditions are flagged.

## Ultra Low Power CO<sub>2</sub> Sensor with T & R/H

### PWM CONTROL - R46

BIT	LABEL	DESCRIPTION	DEFAULT	READ/WRITE
2:0	PRESCALAR	Sets clock pre-scaler, in powers of 2.	00	Read/Write
3	RESOLUTION	0 = 8-bit 1 = 10-bit	0	Read/Write
4	MODE	0 = Pulsed 1 = Always on	0	Read/Write
6:5	OUTPUT	00 = Continuous Output 01 = 2 pulses, then sleeps 10 = 4 pulses, then sleeps 11 = 8 pulses, then sleeps	00	Read/Write
7	ON/OFF	Controls the state of the PWM output	0	Read/Write

### AUTO-ZERO CONTROL – R78

To enable the Auto Zero function write 00000010. To disable write 00000000

To force an auto-zero sequence, do the following.

- Set this register to Enabled (00000010)
- Set R12 auto-zero to target level, or leave at its default setting
- Set R8 interval period to zero

### SELF-TEST – R80

Sensor automatic self test result. Will report 85 if sensor is nominal, 170 if there is an error

### RUN TIME – R90

Reports the total number of hours the sensor has been powered up

### ALTITUDE PRESSURE SETTING – R118

Allows the ambient pressure reading to be input to the sensor in mb. Once loaded to the sensor it is retained after a power cycle. The actual value can be read back if required

## **Ultra Low Power CO<sub>2</sub> Sensor with T & R/H**

### **IMPORTANT NOTICE**

Gas Sensing Solutions Ltd. (GSS) products and services are sold subject to GSS's terms and conditions of sale, delivery and payment supplied at the time of order acknowledgement. GSS warrants performance of its products to the specifications in effect at the date of shipment. GSS reserves the right to make changes to its products and specifications or to discontinue any product or service without notice.

Customers should therefore obtain the latest version of relevant information from GSS to verify that the information is current. Testing and other quality control techniques are utilised to the extent GSS deems necessary to support its warranty. Specific testing of all parameters of each device is not necessarily performed unless required by law or regulation. In order to minimise risks associated with customer applications, the customer must use adequate design and operating safeguards to minimise inherent or procedural hazards. GSS is not liable for applications assistance or customer product design. The customer is solely responsible for its selection and use of GSS products. GSS is not liable for such selection or use nor for use of any circuitry other than circuitry entirely embodied in a GSS product.

GSS products are not intended for use in life support systems, appliances, nuclear systems or systems where malfunction can reasonably be expected to result in personal injury, death or severe property or environmental damage. Any use of products by the customer for such purposes is at the customer's own risk.

GSS does not grant any license (express or implied) under any patent right, copyright, mask work right or other intellectual property right of GSS covering or relating to any combination, machine, or process in which its products or services might be or are used. Any provision or publication of any third party's products or services does not constitute GSS's approval, license, warranty or endorsement thereof. Any third-party trademarks contained in this document belong to the respective third-party owner.

Reproduction of information from GSS datasheets is permissible only if reproduction is without alteration and is accompanied by all associated copyright, proprietary and other notices (including this notice) and conditions. GSS is not liable for any unauthorised alteration of such information or for any reliance placed thereon.

Any representations made, warranties given, and/or liabilities accepted by any person which differ from those contained in this datasheet or in GSS's standard terms and conditions of sale, delivery and payment are made, given and/or accepted at that person's own risk. GSS is not liable for any such representations, warranties or liabilities or for any reliance placed thereon by any person.

### **ADDRESS**

Gas Sensing Solutions Ltd.  
60-62 Grayhill Road  
Cumbernauld  
G68 9HQ  
United Kingdom