

High Speed CO₂ Sensor

DESCRIPTION

The SprintIR®-W (SPR-SEN-0YY-X) previously known as SprintIR®-W is a high flow through NDIR CO₂ sensor using state-of-the-art solid-state LED optical technology. The low power LEDs are manufactured in-house, giving Gas Sensing complete control of the CO₂ sensor signal chain.

The SprintIR®-W (SPR-SEN-0YY-X) is designed for applications that need high response time and high-speed measurement capability. The SprintIR®-W (SPR-SEN-0YY-X) takes 20 readings per second, making it ideal for equipment that needs real-time CO₂ gas analysis or monitoring.

The sensor is available in multiple versions, capable of measuring CO₂ levels up to 100% concentration.

FEATURES

- 20 readings per second
- High flow throughput capability
- Custom flow adaptor options
- $\pm(70+5\% \text{ rdg})$ typical measurement accuracy
- Measurement range up to 100%
- Solid state NDIR LED optical technology
- UART control and data interface
- Built-in auto-zeroing

APPLICATIONS

- Healthcare
- Food Packaging
- Sport Science
- CO₂ Fire Suppression Deployment

BLOCK DIAGRAM

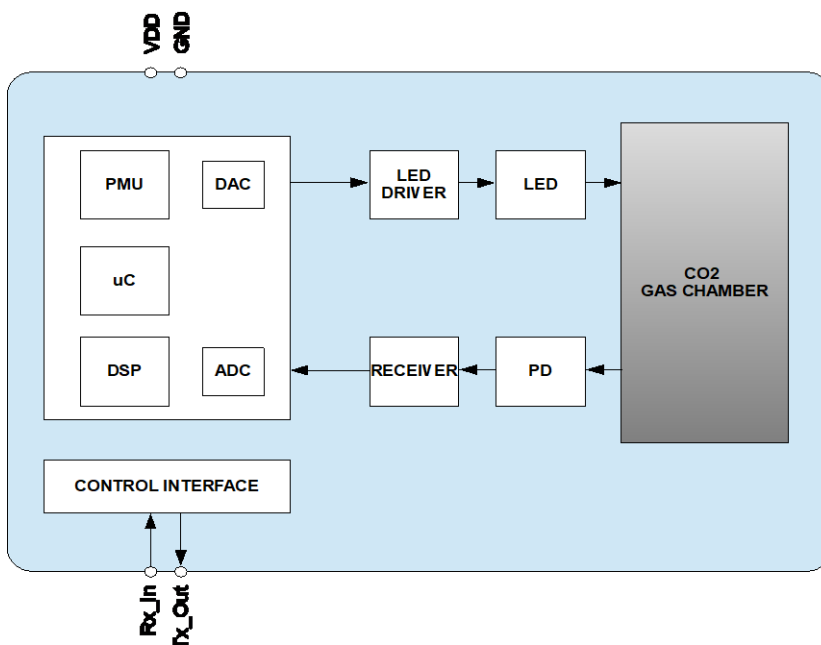

High Speed CO₂ Sensor

Table of Contents

DESCRIPTION..... 1

FEATURES..... 1

APPLICATIONS..... 1

BLOCK DIAGRAM..... 1

ORDERING INFORMATION..... 4

PACKAGE DRAWING: SprintIR®-W (SPR-SEN-025-X) WITH FLOW PORT ADAPTOR 5

PACKAGE DRAWING: SprintIR®-W (SPR-SEN-016-X) WITH MEMBRANE COVER 6

PIN-OUT DESCRIPTION: SprintIR®-W (SPR-SEN-0YY-X) (Either Version)..... 7

ABSOLUTE MAXIMUM RATINGS 8

RECOMMENDED OPERATING CONDITIONS..... 8

MECHANICAL SEALING – For Sensors with Flow Port Adaptor Only 8

CO₂ 2 PERFORMANCE CHARACTERISTICS 9

ELECTRICAL CHARACTERISTICS 10

POWER CONSUMPTION – SPR-SEN-OZY-X 10

INTERFACE TIMING – NITROGEN_ZERO and FRESH_AIR_ZERO..... 11

RESPONSE TIME, FLOW RATE AND MEASUREMENT RATE – SPR-SEN-OZY-X 12

 Measurement Rate..... 12

 Gas Exchange Rate 12

 Digital Filter Setting 12

METHOD OF OPERATION..... 13

MODE 0 COMMAND MODE 13

MODE 1 STREAMING MODE 13

MODE 2 POLLING MODE 13

DIGITAL FILTER 14

ZERO POINT SETTING..... 16

ZERO IN A KNOWN GAS CONCENTRATION 16

ZERO IN NITROGEN..... 16

ZERO IN FRESH AIR 16

ZERO POINT ADJUSTMENT 16

AUTO-ZERO FUNCTION..... 17

AUTO-ZERO INTERVALS 17

AUTO-ZERO SETTINGS 17

PRESSURE AND CONCENTRATION LEVEL COMPENSATION 18

ALTITUDE COMPENSATION TABLE 18

CONTROL INTERFACE 20

CONTROL INTERFACE TIMING - UART MODE 20

UART COMMAND PROTOCOL..... 20

UART OPERATION..... 20

UART INTERFACE SUMMARY 21

CO₂ LEVEL MEASUREMENT VALUE - Z INFORMATION (0x5A) 23

CO₂ LEVEL MEASUREMENT VALUE - z INFORMATION (0x7A)..... 23

‘ ’ COMMAND (0x2E) 23

High Speed CO₂ Sensor

K COMMAND (0x4B)	24
DIGITAL FILTER COMMANDS	25
A COMMAND (0x41)	25
a COMMAND (0x61)	25
ZERO POINT SETTING COMMANDS	26
F COMMAND (0x46)	26
G COMMAND (0x47)	27
U COMMAND (0x55)	27
u COMMAND (0x75)	27
X COMMAND (0x58)	27
P COMMAND - CO ₂ Level for Auto-Zeroing	27
P COMMAND – CO ₂ Level for Zero-Point Setting	28
AUTO-ZEROING INTERVALS	29
@ COMMAND (0x40)	29
PRESSURE AND CONCENTRATION COMPENSATION	30
S COMMAND (0x53)	30
s COMMAND (0x73)	30
MEASUREMENT DATA OUTPUTS	31
M COMMAND	32
Q COMMAND	32
SERIAL NUMBER AND FIRMWARE VERSION	33
Y COMMAND (0x59)	33
CONNECTION DIAGRAM FOR UART INTERFACE	34
IMPORTANT NOTICE	35
ADDRESS	35

High Speed CO₂ Sensor

ORDERING INFORMATION

SPR-SEN-OYY-X

X	Measurement Range
5	0-5%
20	0-20%
60	0-60%
100	0-100%

YY	Flow Adaptor
25	Included
16	Not included

Notes:

1. Sensors are shipped individually
2. Custom flow through adaptors are available, contact Gas Sensing for options

See separate data sheet for SPR-SEN-OYY-X evaluation kit options.

High Speed CO₂ Sensor

PACKAGE DRAWING: SprintIR®-W (SPR-SEN-025-X) WITH FLOW PORT ADAPTOR

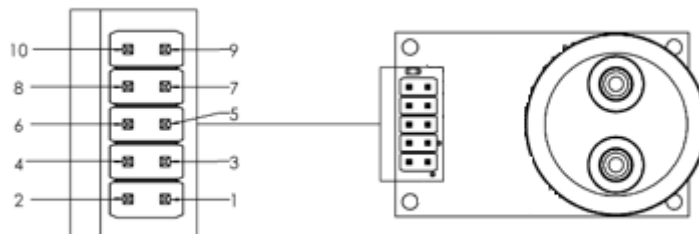
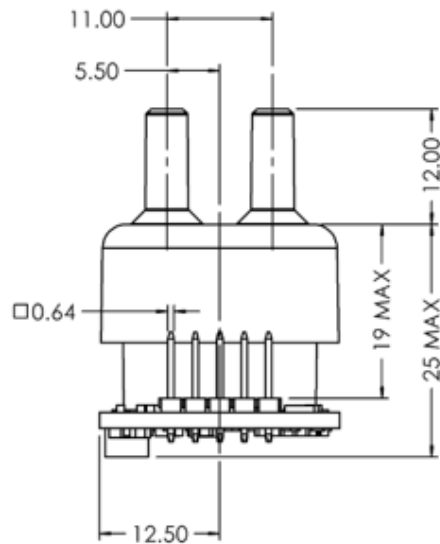
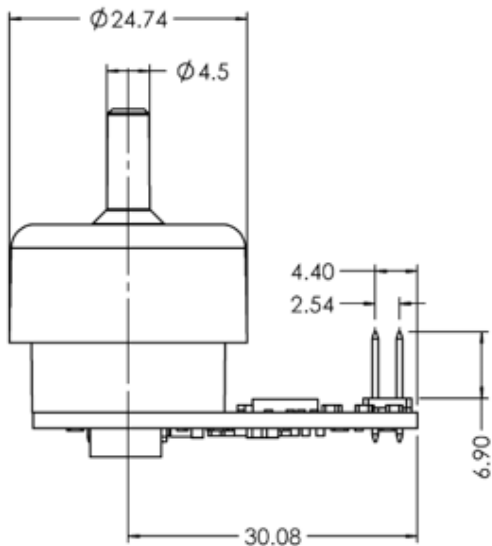
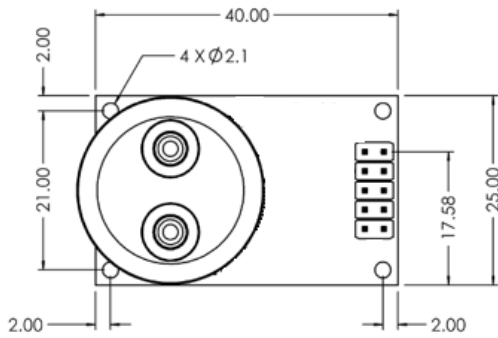

Weight = ~7g

Top View

High Speed CO₂ Sensor

PACKAGE DRAWING: SprintIR®-W (SPR-SEN-016-X) WITH MEMBRANE COVER

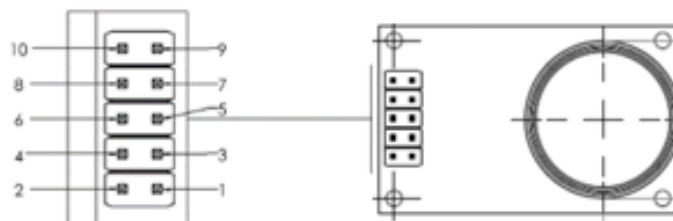
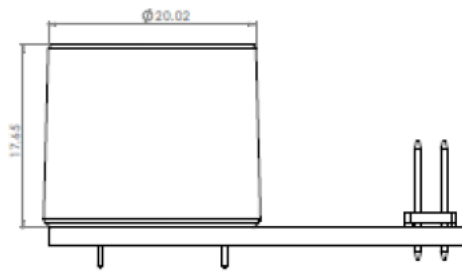
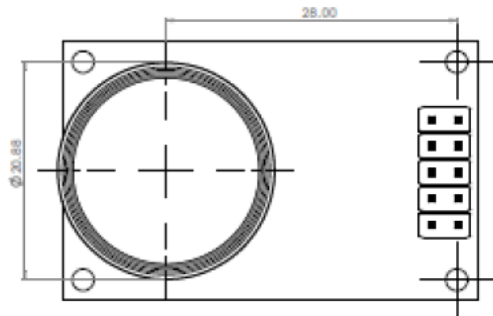

Top View

Weight = ~6g

High Speed CO₂ Sensor

PIN-OUT DESCRIPTION: SprintIR®-W (SPR-SEN-0YY-X) (Either Version)

PIN	NAME	TYPE	DESCRIPTION
1	GND	Supply	Sensor ground
2	NC	Unused	Do Not Connect
3	VDD	Supply	Sensor supply voltage
4	NC	Unused	Do Not Connect
5	Rx_In	Digital Input	UART Receive Input
6	NC	Unused	Do Not Connect
7	Tx_Out	Digital Output	UART Transmit Output
8	NC	Unused	Do Not Connect
9	NC	Unused	Do Not Connect
10	NC	Unused	Do Not Connect

High Speed CO₂ Sensor

ABSOLUTE MAXIMUM RATINGS

Absolute Maximum Ratings are stress ratings only. Permanent damage to the SprintIR®-W (SPR-SEN-OYY-X) may be caused by continuously operating at or beyond these limits. The SprintIR®-W (SPR-SEN-OYY-X) functional operating limits and guaranteed performance specifications are given at the test conditions specified.



ESD Sensitive Device. This sensor uses ESD sensitive components. It is therefore generically susceptible to damage from excessive static voltages. Proper ESD precautions must be taken during handling and storage of this device.

CONDITION	MIN	MAX
Supply Voltages	-0.3V	+6.0V
Voltage Range Digital Inputs	GND -0.3V	5V
Operating Temperature Range (T _a) - Standard	0°C	+50°C
Storage Temperature Range	-40°C	+70°C
Humidity Range (RH), Non-Condensing	0	95%
Operating Ambient Pressure Range	500mbar	2bar

RECOMMENDED OPERATING CONDITIONS

PARAMETER	SYMBOL	MIN	TYP	MAX	UNIT
Supply	VDD	3.25	3.3	5.5	V
Ground	GND		0		V

MECHANICAL SEALING – For Sensors with Flow Port Adaptor Only

CONDITION	MIN	MAX
Working Pressure ¹	0.3bar	
Burst Pressure ²	500mbar	

Test Conditions Unless Otherwise Specified

1. The mechanical sealing between the flow adaptor and sensor housing is tested by pressurising the gas chamber to 0.3bar. The pressure reading must not drop by more than 1mbar within 30 seconds
2. Guaranteed by design, not tested
3. The base of the sensor is NOT guaranteed to be airtight.
4. Sensors with a membrane cover do not have an air-tight seal between the sensor casing and the main sensor body.

High Speed CO₂ Sensor

CO₂ 2 PERFORMANCE CHARACTERISTICS

Test Conditions Unless Otherwise Specified

VDD = 3.3V, GND = 0V. CO₂ = 450ppm, RH = 0% non-condensing, T= 25°C, Pressure = 1013mbar, Flow Rate = 0.2l/minute, Flow Port

PARAMETER	SYMBOL	TEST CONDITIONS	MIN	TYP	MAX	UNIT
CO ₂ measurement range			0		5	%
			0		20	%
			0		60	%
			0		100	%
Accuracy (Peak-Peak) 0-60%		@25°C		±(70 +5%rdg)		ppm
		0°C to +50°C, after auto-zero @25°C		±(70 +5%rdg +~0.1%rdg per °C)		ppm
Accuracy (Peak-Peak) 0-100%		@25°C		±(300 +5%rdg)		ppm
		0°C to +50°C, after auto-zero @25°C		±(300 +5%rdg +~0.1% per °C)		ppm
CO ₂ RMS Noise		Digital filter setting 16		6		ppm
Time to Valid Measurement After Power-On		First value from sensor		0.3		secs
Response Time		T ₉₀ , no filter @ 0.1l/min		3.6		secs
		T ₉₀ , filter = 16 @ 0.1l/min		4.8		
Repeatability		@25°C, 0-60%		±(70 +5%rdg)		ppm
		@25°C, 0-100%		±(300 +5%rdg)		ppm
Current Consumption		Peak current when sampling		35		mA
		Peak at turn-on		150		mA
		SLEEP Mode (K 0 commnad)		0.01		mA

High Speed CO₂ Sensor

ELECTRICAL CHARACTERISTICS

PARAMETER	SYMBOL	TEST CONDITIONS	MIN	TYP	MAX	UNIT
Digital Input/Output						
Input HIGH Level			1.8			V
Input LOW Level					1.0	V
Output HIGH Level		I _{OH} = +1mA	2.6		3.0	V
Output LOW Level		I _{OL} = -1mA			0.4	V

POWER CONSUMPTION – SPR-SEN-OZY-X

Test Conditions Unless Otherwise Specified

VDD = 3.3V, GND = 0V. CO₂ = 450ppm, RH = 0% non-condensing, T= 25°C, Pressure = 1013mbar, Flow Rate = 0.2l/minute

SETTING	SYMBOL	TEST CONDITIONS	VDD		Total Power
			V	I (mA)	mW
Active, K0 SLEEP mode, no measurement			3.3	0.01	0.03
Active, K1 mode whilst taking measurements		Default settings	3.3	9	30

High Speed CO₂ Sensor

INTERFACE TIMING – NITROGEN_ZERO and FRESH_AIR_ZERO

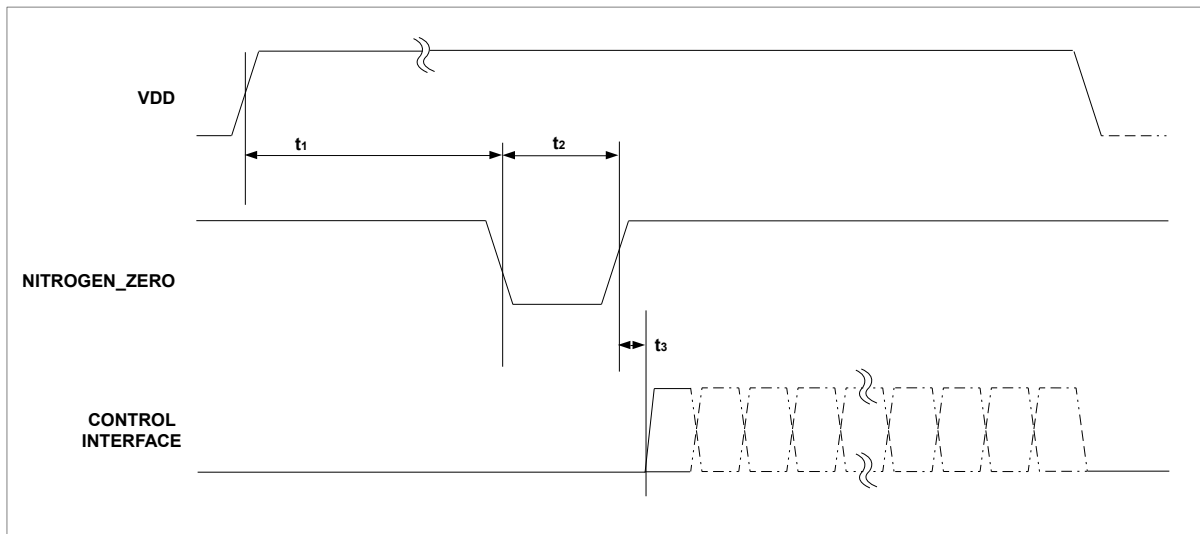

PARAMETER	SYMBOL	MIN	TYP	MAX	UNIT
Power On to NITROGEN_ZERO Ready	t ₁	Time to stable gas			s
NITROGEN_ZERO Low Pulse-Width	t ₂	3			s
Control Interface Setup Time	t ₃	600			ns

Notes

1. The timing for FRESH_AIR_ZERO is identical to NITROGEN_ZERO
2. Ensure gas concentration is stable (t₁) before beginning zeroing process

High Speed CO₂ Sensor

RESPONSE TIME, FLOW RATE AND MEASUREMENT RATE – SPR-SEN-0ZY-X

The SprintIR®-W (SPR-SEN-0YY-X) response time is dependent on several interrelated factors.

Measurement Rate

The measurement rate is fixed at 20 readings per second.

Gas Exchange Rate

The most important factor is the gas exchange rate. This is the amount of time it takes for the gas to enter the CO₂ measurement chamber, measured, and then replaced. The sensor has a gas measurement chamber volume of approximately 2.8ml. As a general rule of thumb, to properly exchange the gas in the chamber, there needs to be a x5 volume of gas passed through the sensor. Therefore, approximately 14ml of gas needs to flow through the sensor for each reading.

$$\text{Max Flow Rate (l/min)} = \frac{20 \text{ reading/s} * 60\text{s} * 14\text{ml}}{1000}$$

Digital Filter Setting

The sensor outputs both filtered and raw unfiltered CO₂ readings. If the filtered measurement data is used, the read rate will also depend on the filter setting or the algorithm to process the raw data.

The table below shows how the response time varies with filter setting and flow rate.

Gas delivery	Measurement frequency (Hz)	T ₅₀ Response time 0.1l/min (s)		T ₅₀ Response time 1l/min (s)	
		No filter	Filter 16	No filter	Filter 16
Flow Adaptor	20	0.7s	1.5s	0.1s	1.3s

Gas delivery	Measurement frequency (Hz)	T ₉₀ Response time 0.1l/min (s)		T ₉₀ Response time 1l/min (s)	
		No filter	Filter 16	No filter	Filter 16
Flow Adaptor	20	3.6s	4.8s	0.3s	2.5s

High Speed CO₂ Sensor

METHOD OF OPERATION

After power is applied to the SprintIR®-W (SPR-SEN-0YY-X), the sensor will automatically start to take CO₂ measurements using the Mode 1 default settings, where the sensor is pre-programmed to send CO₂ measurement data at 20 readings per second.

The measurement rate is fixed at 20 readings per second at a fixed 9600 baud rate. The sensor will return the previous CO₂ measurement results if the user requests more frequent measurements.

The SprintIR®-W (SPR-SEN-0YY-X) has 3 potential modes of operation.

MODE 0 COMMAND MODE

In this mode, the sensor is in a SLEEP mode, waiting for commands. No measurements are made. There is no latency in command responses. All commands that report measurements or alter the zero-point settings are disabled in Mode 0. Mode 0 is NOT retained after power cycling.

MODE 1 STREAMING MODE

This is the factory default setting. Measurements are reported 20 per second. Commands are processed when received, except during measurement activity, so there may be a time delay of up to 10ms in responding to commands.

MODE 2 POLLING MODE

In polling mode, the sensor only reports readings when requested. The sensor will continue to take measurements in the background, but the output stream is suppressed until data is requested. The sensor will always power up in streaming or polling mode, whichever mode was used before the power cycle.

High Speed CO₂ Sensor

DIGITAL FILTER

The CO₂ gas chamber is illuminated with a nominal 4.25um wavelength LED and the signal received using a photodiode. The signal from the photodiode is processed and filtered by the sensor to remove noise and provide an accurate CO₂ reading. High frequency noise coming from the sampling process is removed using a proprietary lowpass filter. The digital filter setting can be varied, allowing the user to reduce measurement noise at the expense of the measurement response time. The ideal digital filter setting is application specific and is normally a balance between CO₂ reading accuracy and response time. The SprintIR®-W (SPR-SEN-OYY-X) sensor will also output the raw unfiltered CO₂ measurement data. This data can be post processed using alternative filter algorithms.

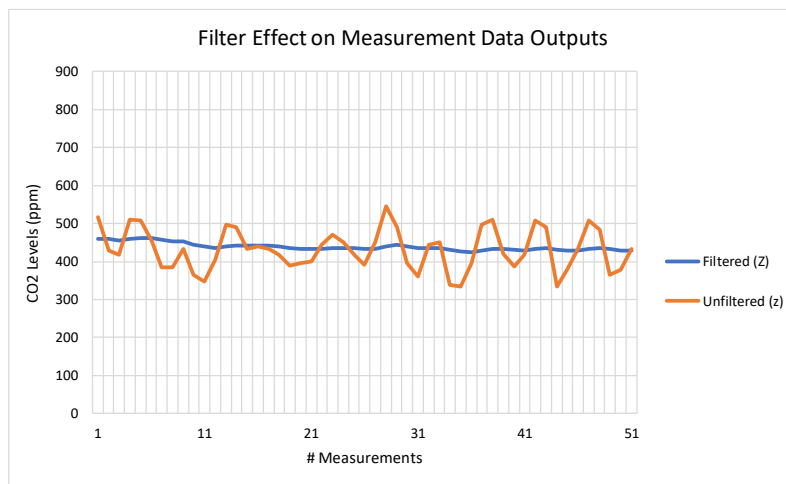

The graph above shows the effects of the filter on the CO₂ measurement data (Z or z). The unfiltered output is shown in orange and the filtered output shown in blue.

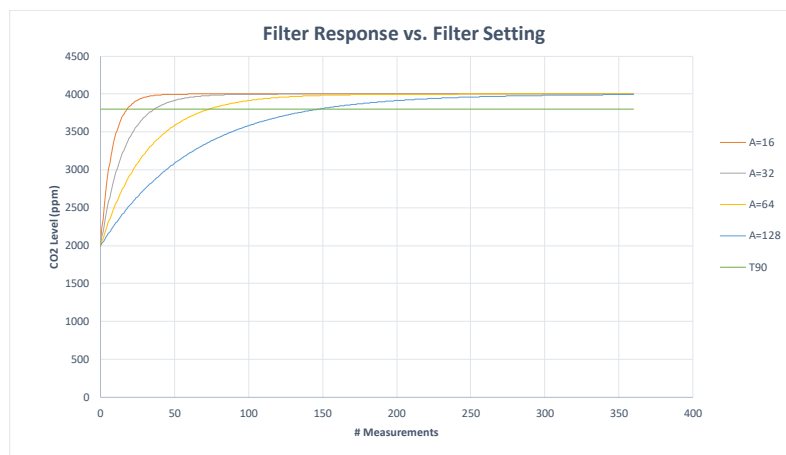

The graph above shows the effect of the filter on response times. Increasing the filter setting increases the measurement output response time. T₉₀ is the time to 90% of reading. The SprintIR®-W (SPR-SEN-OYY-X) takes 20 readings per second. The flow rate was set at 0.2l/min.

High Speed CO₂ Sensor

Sampling noise is progressively reduced with higher digital filter settings. It is recommended the user sets the highest value digital filter setting without compromising the required flow rate.

Flow Rate	Recommended Digital Filter Setting 'a'
0.1litre/minute	64
0.5litre/minute	32
1litre/minute	16
5litre/minute	8

High Speed CO₂ Sensor

ZERO POINT SETTING

There are a several methods available to the user to set the zero point of the sensor. The recommended method is zero-point setting in a known gas concentration. In all cases, the best zero is obtained when the gas concentration is stable, and the sensor is at a stabilised temperature.

Note that zero-point settings are not cumulative and only the latest zero-point setting is effective. For example, there is no benefit in zeroing in nitrogen, and then zeroing in a calibration gas. The sensor will store only the latest zero point.

To improve zeroing accuracy, the recommended digital filter setting is 32. See the 'A' command.

ZERO IN A KNOWN GAS CONCENTRATION

Place the sensor in a known gas concentration, power up the sensor and allow time for the sensor temperature to stabilise, and for the gas to be fully diffused into the sensor.

Send the **ZERO IN A KNOWN GAS CONCENTRATION** command X to the sensor. The sensor will be zeroed using the known gas concentration level sent by the user. The concentration value written to the sensor must be scaled dependent on the sensor CO₂ measurement range. The multiplier for the scaling factor is set according to the range of the sensor, see the '.' command.

ZERO IN NITROGEN

Place the sensor in nitrogen gas and allow time for the sensor temperature to stabilise and the gas to be fully diffused into the sensor. Send the **ZERO IN NITROGEN** command U to the sensor. The sensor is calibrated assuming a 0ppm CO₂ environment.

ZERO IN FRESH AIR

If there is no calibration gas or nitrogen available, the sensor zero point can be set in fresh air. Ambient CO₂ concentrations in fresh air are typically 400ppm. The CO₂ concentration fresh air zero level is programmable over a range from 0ppm to the full scale of the sensor.

Place the sensor in a fresh air environment and allow time for the sensor temperature to stabilise, and for the fresh air to be fully diffused into the sensor. Power up the sensor, write the G command to the sensor. The concentration value written to the sensor must be scaled dependent on the sensor CO₂ measurement range. The sensor can use the default fresh air CO₂ concentration value (400ppm), or the user can write a different fresh air value to the sensor if desired.

ZERO POINT ADJUSTMENT

If the CO₂ concentration and the sensor reported concentration are known, the zero point can be adjusted using the known concentration to fine tune the zero point. For example, if the sensor has been in an environment that has been exposed to outside air, and the sensor reading is known at that time, the zero point can be fine-tuned to correct the reading. This is typically used to implement automated zeroing routines.

High Speed CO₂ Sensor

The known CO₂ concentration value and the reported CO₂ value from the sensor can be sent to the sensor using the **ZERO POINT ADJUSTMENT** command F.

AUTO-ZERO FUNCTION

The sensor has a built-in auto-zeroing function. In order to function correctly, the sensor must be exposed to typical background levels (400-450ppm) at least once during the auto-zeroing period. For example, many buildings will drop quickly to background CO₂ levels when unoccupied overnight or at weekends. The auto-zeroing function uses the information gathered during these periods to re-zero. The sensor will reset the 'zero' level every time it does an auto-zero.

Auto-zeroing is disabled by default. If the sensor is powered down, the auto-zero is reset to default values.

The auto-zero function works in the same way as the **ZERO IN FRESH AIR** command. Auto-zeroing is disabled by default, but can be enabled to operate automatically, or zeroing can be forced. The user can also independently adjust the CO₂ level used for auto-zeroing. Typically, it is set to the same value as the **ZERO IN FRESH AIR** value, but it can also be set at a different level if desired.

AUTO-ZERO INTERVALS

The auto-zeroing period can be programmed by the user. The sensor can be programmed to undertake an initial auto-zero after power-on. Thereafter, the auto-zero period can be set independently of the start-up zeroing time. Note, the auto zeroing timer is reset if the sensor is powered down.

AUTO-ZERO SETTINGS

The sensor will automatically 'zero' using the measured CO₂ level sampled during the auto-zeroing period. The user can alter the behaviour of the sensor as a result of the auto-zero process.

High Speed CO₂ Sensor

PRESSURE AND CONCENTRATION LEVEL COMPENSATION

NDIR gas sensors detect the concentration of gas by measuring the degree of light absorption by the gas analyte. The degree of light absorption is converted into a concentration reported by the sensor.

The absorption process is pressure and gas concentration dependent. In general, as the pressure increases, the reported gas concentration also increases. As the pressure decreases, the reported concentration decreases. This effect takes place at a molecular level and is common to all NDIR gas sensors.

Gas Sensing sensors are calibrated at 1013mbar and 450ppm CO₂. The reading will vary due to pressure and CO₂ concentration. It is possible to correct for the effects of pressure and concentration by setting a compensation value. This will apply a permanent correction to the output of the sensor, depending on the compensation value. The compensation value needs to be written to the sensor and will overwrite the default 1013mbar and 450ppm CO₂ value. The new compensation value will be used for all subsequent measurements and will be retained after a power cycle.

ALTITUDE COMPENSATION TABLE

Altitude (ft.)	Altitude (m)	Pressure (mbar)	Sea Level Difference	% Change per	CO ₂ Measurement Change (%)	Compensation Value
0	0	1,013	0	0.14	0	8,192
500	153	995	18	0.14	3	8,398
1,000	305	977	36	0.14	5	8,605
1,500	458	960	53	0.14	7	8,800
2,000	610	942	71	0.14	10	9,006
2,500	763	925	88	0.14	12	9,201
3,000	915	908	105	0.14	15	9,396
3,500	1,068	891	122	0.14	17	9,591
4,000	1,220	875	138	0.14	19	9,775
4,500	1,373	859	154	0.14	22	9,958
5,000	1,525	843	170	0.14	24	10,142
6,000	1,830	812	201	0.14	28	10,497
7,000	2,135	782	231	0.14	32	10,841
8,000	2,440	753	260	0.14	36	11,174
9,000	2,745	724	289	0.14	40	11,506
10,000	3,050	697	316	0.14	44	11,816

Other compensation values can be calculated using the following formula.

$$\text{Compensation Value} = 8192 + \left(\frac{\text{Sea Level Difference} * 0.14}{100} \right) * 8192$$

High Speed CO₂ Sensor

The pressure compensation values calculated above are only approximate and only valid for concentrations below 1%. For higher accuracy compensation, the sensor output must be adjusted for both pressure and concentration as the CO₂ level measured by the sensor is affected by both ambient pressure and gas concentration levels. To calculate the adjusted CO₂ level, use the following calculation.

$$\text{Corrected CO}_2 \text{ Value} = \frac{\text{CO}_2 \text{ Measurement Value from Sensor (C1)}}{1 + Y(1013 - P)}$$

where,

C1 = Concentration reading from sensor

P = Pressure in mbar

Where concentration is < 1500ppm.

$$Y = 2.6661 \times 10^{-16} x C1^4 - 1.1146 \times 10^{-12} x C1^3 + 1.7397 \times 10^{-9} x C1^2 - 1.2556 \times 10^{-6} x C1 - 9.8754 \times 10^{-4}$$

Where concentration is >1500ppm.

$$Y = 2.811 \times 10^{-38} x C1^6 - 9.817 \times 10^{-32} x C1^5 + 1.304 \times 10^{-25} x C1^4 - 8.126 \times 10^{-20} x C1^3 + 2.311 \times 10^{-14} x C1^2 - 2.195 \times 10^{-9} x C1 - 1.471 \times 10^{-3}$$

High Speed CO₂ Sensor

CONTROL INTERFACE

The SPR-SEN family of sensors are controlled by writing and reading from the sensor via its UART interface. The Rx_In and Tx_Out pins are normally high, suitable for direct connection to a UART. If the sensor is to be read by a true RS232 device (e.g. a PC), it is necessary to pass through a level converter to step up/down the voltage and invert the signal.

CONTROL INTERFACE TIMING - UART MODE

PARAMETER	SYMBOL	MIN	TYP	MAX	UNIT
Baud Rate			9600		Bits/s
Data Bits			8		
Parity			None		
Stop Bits			1		
Hardware Flow Control			None		

UART COMMAND PROTOCOL

All UART commands must be terminated with a carriage return and line feed <CR><LF>, hex 0x0D 0x0A. In this document, this is shown as '\r\n'. UART commands that take a parameter always have a space between the letter and the parameter. The sensor will respond with a '?' if a command is not recognised. The two most common causes are missing spaces or missing <CR><LF> terminators.

All command communications are in ASCII and are terminated by carriage return, line feed (0x0D 0x0A). This document uses the protocol "\r\n" to indicate the carriage return line feed. All responses from the sensor, including measurements, have a leading space (ASCII character 32).

The character '#' represents an ASCII representation of a numeric character (0-9). Note there is a space between the first letter and any parameter. For example, the X command reads "X space 2000 carriage return line feed".

UART OPERATION

When initially powered, the sensor will immediately start to transmit a CO₂ reading on receiving any character.

The CO₂ measurement is reported as:

Z #####\r\n

where Z ##### shows the CO₂ concentration.

Note that all outputs from the sensor have a leading space.

High Speed CO₂ Sensor

UART INTERFACE SUMMARY

Syntax	Use	Example	Response	Comments
A ###\r\n	Set value of the digital filter	A 32\r\n	A 00032\r\n	See “Digital Filter”
a\r\n	Return the value of the digital filter	a\r\n	a 00128\r\n	See “Digital Filter”
F #####\r\n	Fine Tune the zero point	F 410 400\r\n	F 33000\r\n	See “Zero Point Setting”
G\r\n	Zero-point setting using fresh air	G\r\n	G 33000\r\n	See “Zero Point Setting”
K #\r\n	Switches the sensor between different modes	K 1\r\n	K 00001\r\n	
M #####\r\n	Sets the number of measurement data types output by the sensor	M 6\r\n	M 00006\r\n	See “Measurement Data Outputs”
P 0 ###\r\n P 1 #\r\n	Sets the CO ₂ reading for maximum voltage output level	P 0 19\r\n P 1 136\r\n	P 00000 00019\r\n P 00001 00136\r\n	Two byte value, P 0 = MSB P 1 = LSB 5000ppm in the example
P 8 ###\r\n P 9 #\r\n	Sets value of CO ₂ background concentration in ppm for auto-zeroing	P 8 1\r\n P 9 144\r\n	P 00008 00001\r\n P 00009 00144\r\n	Two-byte value, P 8 = MSB P 9 = LSB 400ppm in the example
P 10 ###\r\n P 11 #\r\n	Sets value of CO ₂ background concentration in ppm used for zero-point setting in fresh air.	P 10 1\r\n P 11 144\r\n	P 00010 00001\r\n P 00011 00144\r\n	Two-byte value, P 10 = MSB P 11 = LSB 400ppm in the example
Q\r\n	Reports the latest measurement data types, as defined by ‘M’	Q\r\n	H 12345 T 12345 Z 00010\r\n	
S #####\r\n	Sets the pressure and concentration compensation value	S 8192\r\n	S 08192\r\n	See “Pressure and Concentration Compensation”
s\r\n	Returns the pressure and concentration compensation value	s\r\n	s 08192\r\n	See “Pressure and Concentration Compensation”
U\r\n	Zero-point setting using nitrogen	U\r\n	U 33000\r\n	See “Zero Point Setting”
u #####\r\n	Manual setting of the zero point.	u 32997\r\n	u 32997\r\n	See “Zero Point Setting”
X #####\r\n	Zero-point setting using a known gas calibration	X 2000\r\n	X 32997\r\n	See “Zero Point Setting”

High Speed CO₂ Sensor

Syntax	Use	Example	Response	Comments
Y\r\n	Return firmware version and sensor serial number	Y\r\n	Returns <u>two</u> lines	
Z\r\n	Return the most recent filtered CO ₂ measurement in ppm	Z\r\n	Z 01521\r\n	
z\r\n	Return the most recent unfiltered CO ₂ measurement in ppm	z\r\n	Z 01521\r\n	
@ #.#.#.\r\n	Sets the timing for initial and interval auto-zeroing periods	@ 1.0 8.0\r\n	@ 1.0 8.0\r\n	See “Auto-zeroing” for details
@\r\n	Returns the auto-zeroing configuration	@ 1.0 8.0\r\n	@ 1.0 8.0\r\n	See “Auto-zeroing” for details
@ 0\r\n	Switch auto-zeroing on or off	@ 0\r\n	@ 0\r\n	See “Auto-zeroing” for details
.\r\n	Returns the scaling factor multiplier required to convert the Z or z output to ppm	.\r\n	. 00010\r\n	Multiply by 10 in the example

High Speed CO₂ Sensor

CO₂ LEVEL MEASUREMENT VALUE - Z INFORMATION (0x5A)

Description	Reports the latest filtered CO ₂ measurement
Syntax	ASCII Character 'Z', terminated by 0x0D 0x0A (CR & LF)
Example	Z\r\n
Response	Z 00521\r\n

This value needs to be multiplied by the appropriate scaling factor to derive the ppm value. See the '.' command.

CO₂ LEVEL MEASUREMENT VALUE - z INFORMATION (0x7A)

The sensor is also capable of reporting the real time unfiltered CO₂ measurement value.

Description	Reports the unfiltered CO ₂ measurement
Syntax	ASCII Character 'z', terminated by 0x0D 0x0A (CR & LF)
Example	z\r\n
Response	z 00521\r\n

'.' COMMAND (0x2E)

To calculate the measurement value in ppm, the 'Z' or 'z' value, they must be converted into ppm by using the '.' multiplier factor. This multiplier will depend on the full-scale measurement range of the sensor. The multiplier is related to the full-scale range of the sensor.

The multiplier must also be used when sending CO₂ concentration levels to the sensor, for example when setting the fresh air CO₂ concentration value. The '.' Command can also be used to read back the scaling factor.

For example, if the user wants to zero the sensor in a known concentration of gas (e.g. 450ppm), the value written to the sensor must be 450/scaling factor.

Description	Returns a number indicating what multiplier must be applied to the Z CO ₂ measurement output to convert it into ppm.
Syntax	ASCII character '.', terminated by 0x0D 0x0A (CR & LF)
Example	.\r\n
Response	. 00010\r\n (this number is variable, usually 10)

Measurement Range of Sensor	CO ₂ Measurement Scaling Factor (Z)	CO ₂ Measurement Output Units	Example
0 – 60%	10	ppm/10	Z 01200 = 12,000ppm = 1.2%
0 – 100%	100	ppm/100	Z 01500 = 150,000ppm = 15%

High Speed CO₂ Sensor

K COMMAND

The SPR-SEN-OZY-Xhas 3 potential modes of operation, controlled by the K command.

Mode	Value	Description	
Mode 0	K=0	Sleep Mode	Sensor is in a SLEEP mode, waiting for commands. No measurements are made. There is no latency in command responses. All commands that report measurements or alter the zero-point settings are disabled in Mode 0. Mode 0 is NOT retained after power cycling.
Mode 1	K=1	Streaming Mode	This is the factory default setting. Measurements are reported twice per second. Commands are processed when received, except during measurement activity, so there may be a time delay of up to 100ms in responding to commands.
Mode 2	K=2	Polling Mode	In polling mode, the sensor only reports readings when requested. The sensor will continue to take measurements in the background, but the output stream is suppressed until data is requested. The sensor will always power up in streaming or polling mode, whichever mode was used before the power cycle.

Command	Use	Default	Range	Example	Response	Comments
K #\r\n	Switches the sensor between different control modes	1		K 1\r\n	K 1\r\n	<i>See 'K' Commands</i>

K COMMAND (0x4B)

Description	Sets the control interface mode
Syntax	ASCII character 'K', SPACE, mode number, terminated by 0x0D 0x0A (CR & LF)
Example	K 1\r\n
Response	K 00001\r\n (this number is variable)

High Speed CO₂ Sensor

DIGITAL FILTER COMMANDS

Command	Use	Default	Range	Example	Response	Comments
A ###\r\n	Set value of the digital filter	16	1 - 65535	A 16\r\n	A 00016\r\n	
a\r\n	Return value of digital filter		1 - 65535	a\r\n	a 00016\r\n	

A COMMAND (0x41)

Description	Set the value for the digital filter
Syntax	ASCII character 'A', SPACE, decimal, terminated by 0x0D 0x0A (CR & LF)
Example	A 16\r\n
Response	A 00016\r\n (this number is variable)

a COMMAND (0x61)

Description	Set the value for the digital filter
Syntax	ASCII character 'A', SPACE, decimal, terminated by 0x0D 0x0A (CR & LF)
Example	A 16\r\n
Response	A 00016\r\n (this number is variable)

High Speed CO₂ Sensor

ZERO POINT SETTING COMMANDS

Command	Use	Default	Range	Example	Response	Comments
F ##### #####\r\n	Fine Tune the zero point		Range of sensor	F 410 400\r\n	F 33000\r\n	See "Zero Point Setting"
G\r\n	Zero-point setting using fresh air			G\r\n	G 33000\r\n	See "Zero Point Setting"
U\r\n	Zero-point setting using nitrogen			U\r\n	U 33000\r\n	See "Zero Point Setting"
u #####\r\n	Manual setting of the zero point			u 32997\r\n	u 32997\r\n	See "Zero Point Setting"
X #####\r\n	Zero-point setting using a known gas concentration		Range of sensor	X 2000\r\n	X 32997\r\n	See "Zero Point Setting"
P 8 ###\r\n P 9 #\r\n	Sets value of CO ₂ background concentration in ppm for auto-zeroing	P 8 1\r\n P 9 144\r\n		P 8 1\r\n P 9 144\r\n	P 00008 00001\r\n P 00009 00144\r\n	Two-byte value, P 8 = MSB P 9 = LSB 400ppm in the example
P 10 ###\r\n P 11 #\r\n	Sets value of CO ₂ background concentration in ppm used for zero- point zeroing in fresh air.	P 10 1\r\n P 11 144\r\n		P 10 1\r\n P 11 144\r\n	P 00010 00001\r\n P 00011 00144\r\n	Two-byte value, P 10 = MSB P 11 = LSB 400ppm in the example

F COMMAND (0x46)

Description	Calibrates the zero-point using a known reading and a known CO ₂ concentration terminated by 0x0D 0x0A (CR & LF)
Syntax	ASCII character 'F', SPACE, then the reported gas concentration, SPACE, then the actual gas concentration, terminated by 0x0D 0x0A (CR & LF)
Example	F 41 39\r\n
Response	F 33000\r\n (the numbers are variable)

High Speed CO₂ Sensor

G COMMAND (0x47)

Description	Sets the zero point assuming the sensor is in fresh air (typically 400ppm CO ₂ , but level can be set by user – see P commands.)
Syntax	ASCII character 'G' terminated by 0x0D 0x0A (CR & LF)
Example	G\r\n
Response	G 33000\r\n (the number is variable)

U COMMAND (0x55)

Description	Sets the zero point assuming the sensor is in 0ppm CO ₂ such as nitrogen.
Syntax	ASCII Character 'U' terminated by 0x0D 0x0A (CR & LF)
Example	U\r\n
Response	U 32767\r\n (the number is variable)

u COMMAND (0x75)

Description	Forces a specific zero set point value. Input value is scaled by CO ₂ value multiplier, see '.' command.
Syntax	ASCII character 'u', SPACE, then the gas concentration, terminated by 0x0D 0x0A (CR & LF)
Example	u 32767\r\n
Response	u 32767\r\n

X COMMAND (0x58)

Description	Sets the zero point with the sensor in a known concentration of CO ₂ . Input value is scaled by CO ₂ value multiplier, see '.' command.
Syntax	ASCII character 'X', SPACE, then the gas concentration, terminated by 0x0D 0x0A (CR & LF)
Example	X 1000\r\n
Response	X 33000\r\n (the number is variable).

P COMMAND - CO₂ Level for Auto-Zeroing

Description	Sets the value of CO ₂ in ppm used for auto-zeroing. Input value is scaled by CO ₂ value multiplier, see '.' command.
Syntax	ASCII character 'P', SPACE, then 8, SPACE, then MSB terminated by 0x0D 0x0A (CR & LF) ASCII character 'P' then a space, then 9, then a space, then LSB terminated by 0x0D 0x0A (CR & LF)
Example	P 8 0\r\n P 9 40\r\n
Response	p 8 0\r\n p 9 40\r\n

The value is entered as a two-byte word, MSB first.

High Speed CO₂ Sensor

MSB = Integer (Concentration/256)

LSB = Concentration – (256*MSB)

In the above example, target CO₂ background concentration is 400ppm.

MSB = Integer (400/256) = 1

LSB = 400 – 256 = 144

P COMMAND – CO₂ Level for Zero-Point Setting

Description	Sets value of CO ₂ in ppm for zero-point setting in fresh air. Input value is scaled by CO ₂ value multiplier, see '.' command.
Syntax	ASCII character 'P', SPACE, then 10, SPACE, then MSB terminated by 0x0D 0x0A (CR & LF) ASCII character 'P', SPACE, then 11, SPACE, then LSB terminated by 0x0D 0x0A (CR & LF)
Example	P 10 7\r\n P 11 208\r\n
Response	p 10 7\r\n p 11 208\r\n

MSB = Integer (Concentration/256)

LSB = Concentration – (256*MSB)

In the above example, target zero-point CO₂ concentration is 2000ppm.

MSB = Integer (2000/256) = 7

LSB = 2000 – (256*MSB) = 208

High Speed CO₂ Sensor

AUTO-ZEROING INTERVALS

UART Command	Use	Default	Range	Example	Response	Comments
@ #.#.#.#\r\n	Auto-zeroing interval settings			@ 1.0 8.0\r\n	@ 1.0 8.0\r\n	See "Auto-Zeroing" for details

@ COMMAND (0x40)

Description	Set the 'Initial Interval' and 'Regular Interval' for auto-zeroing events.
Syntax	ASCII character '@', SPACE, decimal, SPACE, decimal terminated by 0x0D 0x0A (CR & LF)
Example	@ 1.0 8.0\r\n
Response	@ 1.0 8.0\r\n (the number mirrors the input value)

Both the initial interval and regular interval are given in days. Both must be entered with a decimal point and one figure after the decimal point. In the above example, the auto-zero interval is set to 8 days, and the initial interval set to 1 day.

- On this sensor type, auto-zero is disabled by default
- To enable auto-zero, send interval as required @ 1.0 8.0\r\n
- To disable auto-zero, send @ 0\r\n
- To determine the auto-zero configuration, send @\r\n

High Speed CO₂ Sensor

PRESSURE AND CONCENTRATION COMPENSATION

UART Command	Use	Default	Range	Example	Response	Comments
S #####\r\n	Sets the pressure and concentration compensation value	8192	0-65536	S 8192\r\n	S 08192\r\n	See <i>"Pressure and Concentration Compensation"</i>
s\r\n	Returns the pressure and concentration compensation value			s\r\n	s 08192\r\n	See <i>"Pressure and Concentration Compensation"</i>

S COMMAND (0x53)

Description	Set the 'Pressure and Concentration Compensation' value
Syntax	ASCII character 'S', SPACE, decimal, terminated by 0x0D 0x0A (CR & LF)
Example	S 8192\r\n
Response	S 8192\r\n (the number mirrors the input value)

s COMMAND (0x73)

Description	Reports the 'Pressure and Concentration Compensation' value.
Syntax	ASCII Character 's', terminated by 0x0D 0x0A (CR & LF)
Example	s\r\n
Response	s 8192\r\n

High Speed CO₂ Sensor

MEASUREMENT DATA OUTPUTS

The sensor can send multiple fields of data as a single string. Up to five data fields can be transmitted, programmable by the user. The number of fields and the type of data to be transmitted is defined by the “Mask Value” setting.

The output data format is as follows. Each field is identified by the Data Field Identifier character, followed by a space, followed by the five-digit number indicating the value of the parameter.

Data Parameter	Data Field Identifier	Mask Value	Description
D digitally filtered	d	2048	Reports a value related to the normalized LED signal strength (smoothed)
D unfiltered	D	1024	Reports a value related to the normalized LED signal strength
Zero Set Point	h	256	Reports a value related to the normalized LED signal strength
Sensor Temperature (unfiltered)	V	128	Reports a value that varies inversely with the sensor temperature.
LED Signal (digitally filtered)	o	32	Reports a value that gives an indication of the LED signal strength (smoothed)
LED Signal (unfiltered)	O	16	Reports a value that gives an indication of the LED signal strength.
Sensor Temperature (filtered)	v	8	Reports a value that varies inversely with the sensor temperature. (smoothed)
CO ₂ Output (Filtered)	Z	4	Filtered CO ₂ reading
CO ₂ Output (Unfiltered)	z	2	Raw CO ₂ reading, unfiltered

UART Command	Use	Default	Range	Example	Response	Comments
M #####\r\n	Sets the number of measurement data types output by the sensor. ##### is the mask value	M 00006\r\n		See “Output Fields”	M #####\r\n	Sets the number of measurement data types output by the sensor

High Speed CO₂ Sensor

The required mask value is the sum of the 'Mask Value' for each field required. To output filtered and unfiltered CO₂ data, set M=6.

To output the temperature, humidity and CO₂ measurements, set M = 4164 (send M 4164\r\n).

The output string will be: H 12345 T 12345 Z 00010\r\n

M COMMAND

Description	Sets the type and number of data outputs
Syntax	ASCII character 'M', SPACE, up to 5 digit number, terminated by 0x0D 0x0A (CR & LF)
Example	M 6\r\n
Response	M 00006\r\n

Q COMMAND

Description	Reports the latest output data fields defined by 'M'
Syntax	ASCII character 'Q', terminated by 0x0D 0x0A (CR & LF)
Example	Q\r\n
Response	H 12345 T 12345 Z 00010\r\n

High Speed CO₂ Sensor

SERIAL NUMBER AND FIRMWARE VERSION

UART Command	Use	Default	Range	Example	Response	Comments
Y\r\n	Return firmware version and sensor serial number			Y\r\n	Returns <u>two</u> lines	

Y COMMAND (0x59)

Description	The present version string for the firmware and serial number of the sensor.
Syntax	ASCII character 'Y', terminated by 0x0d 0x0a (CR & LF)
Example	Y\r\n
Response	Y, Aug 25 2021, 14:19:56, LP15132 B 528148 00000 Where; Aug 25 2021, 14:19:56 is the firmware compile date and time LP15132 is the firmware revision 528148 is the sensor ID

N.B. This command returns two lines split by a carriage return line feed and terminated by a carriage return line feed. This command requires that the sensor has been stopped (see 'K' command).

High Speed CO₂ Sensor

CONNECTION DIAGRAM FOR UART INTERFACE

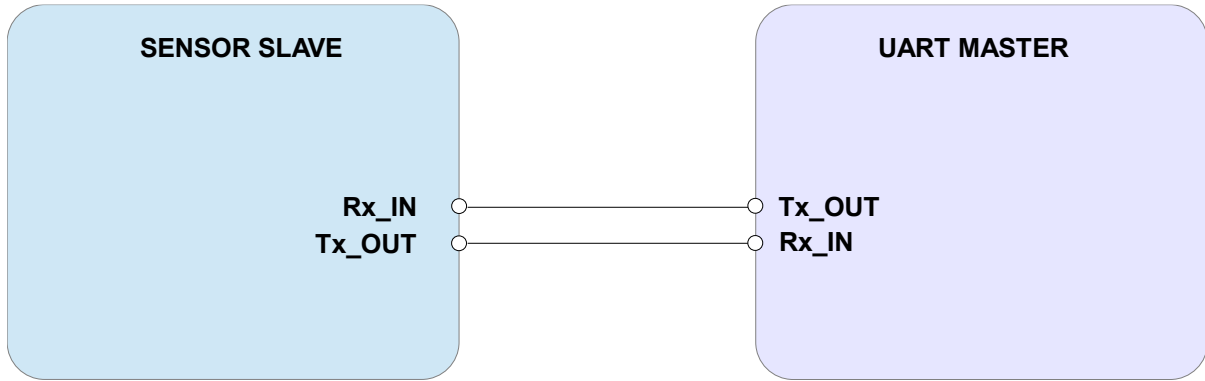

High Speed CO₂ Sensor

IMPORTANT NOTICE

Gas Sensing Solutions Ltd. (Gas Sensing) products and services are sold subject to Gas Sensing's terms and conditions of sale, delivery and payment supplied at the time of order acknowledgement. Gas Sensing warrants performance of its products to the specifications in effect at the date of shipment. Gas Sensing reserves the right to make changes to its products and specifications or to discontinue any product or service without notice.

Customers should therefore obtain the latest version of relevant information from Gas Sensing to verify that the information is current. Testing and other quality control techniques are utilised to the extent Gas Sensing deems necessary to support its warranty. Specific testing of all parameters of each device is not necessarily performed unless required by law or regulation. In order to minimise risks associated with customer applications, the customer must use adequate design and operating safeguards to minimise inherent or procedural hazards. Gas Sensing is not liable for applications assistance or customer product design. The customer is solely responsible for its selection and use of Gas Sensing products. Gas Sensing is not liable for such selection or use nor for use of any circuitry other than circuitry entirely embodied in a Gas Sensing product.

Gas Sensing products are not intended for use in life support systems, appliances, nuclear systems or systems where malfunction can reasonably be expected to result in personal injury, death or severe property or environmental damage. Any use of products by the customer for such purposes is at the customer's own risk.

Gas Sensing does not grant any licence (express or implied) under any patent right, copyright, mask work right or other intellectual property right of Gas Sensing covering or relating to any combination, machine, or process in which its products or services might be or are used. Any provision or publication of any third party's products or services does not constitute Gas Sensing's approval, licence, warranty or endorsement thereof. Any third-party trademarks contained in this document belong to the respective third-party owner.

Reproduction of information from Gas Sensing datasheets is permissible only if reproduction is without alteration and is accompanied by all associated copyright, proprietary and other notices (including this notice) and conditions. Gas Sensing is not liable for any unauthorised alteration of such information or for any reliance placed thereon.

Any representations made, warranties given, and/or liabilities accepted by any person which differ from those contained in this datasheet or in Gas Sensing's standard terms and conditions of sale, delivery and payment are made, given and/or accepted at that person's own risk. Gas Sensing is not liable for any such representations, warranties or liabilities or for any reliance placed thereon by any person.

ADDRESS

Gas Sensing Solutions Ltd.
Grayshill Road
Cumbernauld
G68 9HQ
United Kingdom

High Speed CO₂ Sensor

REVISION HISTORY

DATE	RELEASE	DESCRIPTION OF CHANGES	PAGES
16/04/2020	4.0	First revision	All
28/04/2020	4.1	Changed zero settings language	All
11/06/2020	4.2	Absolute Maximum Ratings, Mechanical Sealing	P. 8
18/11/2020	4.3	Absolute Maximum Ratings	P.7
15/01/2021	4.4	INTERFACE TIMING – NITROGEN_ZERO and FRESH_AIR_ZERO	p.12
19/01/2021	4.5	'.' COMMAND (0x2E)	P.25
01/02/2021	4.6	Absolute Maximum Ratings	P.7
21/06/2021	4.7	Updated T90 response times	P.8, P.12
23/06/2021	4.8	@ COMMAND UPDATE	P.29
18/08/2021	4.9	Updated data output fields	P.32
27/09/2021	4.10	Y Command	P.34
08/12/2021	4.11	Various minor corrections	All
29/05/2024	4.12	Change to new part number ordering format	All
22/01/2024	4.13	Remove V and T & RH options	Various
30/01/2024	4.14	Remove Nitrogen and Fresh Air hardware options and update block diagram	Various
07/01/2026	4.15	Remove H command references	P.21 and P.31